

2024 MODEL Update/Validation
Pueblo Planning Model
Methodology Report

PACOG
MOVES THE REGION

2024 MODEL
UPDATE

June 2024

Table of Contents

1 Introduction..... 1

1.1 The Need for Travel Demand Models 1

1.2 Background of the PACOG Travel Model..... 1

1.3 The Traffic Forecasting Modeling Process 3

2 Traffic Analysis Zones and Socioeconomic Data Development 4

2.1 Overview 4

2.2 Traffic Analysis Zones 4

2.3 Socioeconomic Data Development 4

2.3.1 Overview of Data Sources..... 4

2.3.2 Household & Population Data Development 5

2.3.3 School Populations..... 6

2.3.4 Employment Data Development..... 7

2.3.5 Summary..... 8

2.4 Travel Model External Zones/Stations 8

2.4.1 The Eight PACOG Model External Stations 8

2.4.2 Estimating Base Year External Station Volumes..... 9

2.4.3 Estimating Future External Station Volumes 10

2.5 Area Type 10

3 Highway Network Update 13

3.1 Background..... 13

3.2 Base Year Network Development 13

3.3 Development of Link Speeds and Lane Capacities..... 13

3.4 Node Attributes 15

3.5 Link Attributes 15

3.6 Time of Day Capacity Assumptions..... 20

3.7 Turn Movements and Prohibitions/Penalties 20

4 Truck Model..... 21

4.1 Truck Model Approach..... 21

4.2 Truck Trip Generation and Distribution..... 22

4.3 Truck Model Validation 23

5 Trip Generation..... 24

5.1 Overview of Components 25

5.1.1 Household Trip Generation 25

5.1.2 Truck Trip Generation 25

5.1.3 Special Trip Generators 25

5.2 Household Socioeconomic Disaggregation..... 26

5.2.1 Household Income Categories 26

5.2.2 Household Trip Production Model 26

5.2.3	Trip Purposes	26
5.2.4	Cross-Classification Approach	27
5.3	Trip Attraction Models	30
5.3.1	Home-Based Work (HBW)	30
5.3.2	Home-Based School (School)	30
5.3.3	Home-Based Shop (HBSshop)	30
5.3.4	Home-Based Other (HBO)	32
5.3.5	Non-Home Based Work (NHBW)	32
5.3.6	Non-Home Based Other (NHBO)	32
5.4	External Trip Model.....	32
5.5	Work from Home (WFH) Adjustment to Work Trip Rates.....	32
5.5.1	Rationale for Work Trip Rate Adjustment.....	32
5.5.2	Work from Home Development and Application.....	33
5.6	Validation of Attraction-Production Models.....	35
5.6.1	Introduction to Trip Production	35
5.6.2	Trip Production Validation	36
5.6.3	Trip Production Ratio Validation	37
5.6.4	Total Productions versus Total Attractions	37
5.7	Summary.....	38
6	Special Generators.....	39
6.1	Introduction	39
6.2	Pueblo Airport (PUB)	39
7	Distribution Model.....	41
7.1	PACOG Distribution Model Formulation.....	41
7.2	Distribution Model Development.....	42
7.2.2	Gravity Model Calibration	42
7.2.3	External-External Trip Distribution.....	46
8	PACOG Transit Modeling	47
8.1	Pueblo Transit System.....	47
8.2	Pueblo Transit Model Processing for Mode Split.....	48
9	Mode Choice	50
9.1	Introduction	50
9.2	Formulation and Nesting Structure	51
9.3	Mode Choice Model Implementation	53
9.4	Observed Mode Shares and Model Sensitivity.....	53
9.5	Post Mode Choice Trip Processing	54
9.6	Time of Day Modeling and Directional Split Factors	54
10	Highway and Transit Assignment Approach	59
10.1	Highway Assignment	59
10.2	Transit Assignment.....	59

11 User Interface, GHG Analysis and Reporting.....60

 11.1 Greenhouse Gas Reduction Scenarios60

12 Daily Model Validation61

 12.1 Observed Traffic Data..... 61

 12.2 Validation Approach..... 62

 12.2.1 Traffic Validation Link Categories.....62

 12.2.2 Daily Highway Model Validation Tests62

 12.3 Highway Model Validation Results 63

 12.3.1 Validation by Facility Type.....63

 12.3.2 Validation by Volume Range63

 12.3.3 Validation by Screenline.....64

 12.3.4 Validation by Scatterplot.....65

 12.3.5 Summary of Highway Validation65

List of Figures

Figure 1: PACOG TAZ Layer and Travel Model Extent..... 3

Figure 2: Census Block and PACOG TAZ Geography 6

Figure 3: Location of PACOG External Stations 9

Figure 4: Area Type 11

Figure 5: Area Type (Inset) 12

Figure 6: 2020 Link Facility Type 18

Figure 7: 2020 Link Facility Type Inset 19

Figure 8: FHWA Truck Vehicle Classification 22

Figure 9: SUT Validation Scatterplot.....23

Figure 10: MUT Validation Scatterplot 24

Figure 11: Front Range 2010 Surveyed Households 27

Figure 12: Midpoint Designation for Pueblo County WFH Percentages..... 34

Figure 13: Pueblo Airport Area 40

Figure 14: Home-Based Work Trip Length Frequency Comparison 42

Figure 15: Home-Based Shopping Trip Length Frequency Comparison..... 43

Figure 16: Home-Based Other Trip Length Frequency Comparison 43

Figure 17: Home-Based Elementary & Middle School Trip Length Frequency Comparison 44

Figure 18: Non-Home-Based Work Trip Length Frequency Comparison..... 44

Figure 19: Non-Home-Based Other Trip Length Frequency Comparison 45

Figure 20: Pueblo Transit System, Observed and Modeled 47

Figure 21: Mode Choice Nesting Structure..... 51

Figure 22: Viewing the Mode Choice Model Structure 53

Figure 23: Home-Based Work Time of Day of Travel..... 56

Figure 24: Home-Based Shop Time of Day of Travel..... 56

Figure 25: Home-Based Other Time of Day of Travel 57

Figure 26: Non-Home-Based Time of Day of Travel 57

Figure 27: All Trips Time of Day of Travel 58

Figure 28: AADT Count Locations 61

Figure 29: Location of PACOG Travel Model Screenlines 64
 Figure 30: Scatterplot of all Counted Link Segments 65

List of Tables

Table 1: PACOG 2024 Traffic Analysis Zone Summary 4
 Table 2: Zonal Attributes for the TAZ Layer 4
 Table 3: Socioeconomic Attributes 5
 Table 4: PACOG Employment Categories by NAICS Code 7
 Table 5: Colorado Department of Local Affairs (DOLA) Totals for Pueblo County 8
 Table 6: Colorado Department of Local Affairs (DOLA) Growth Rates for Pueblo County 8
 Table 7: PACOG Model External Stations 8
 Table 8: PACOG Model External Station Observed Traffic 10
 Table 9: External Station Future Year Traffic Counts Estimation 10
 Table 10: Number of TAZs by Area Type 11
 Table 11: PACOG Link Functional Class 13
 Table 12: PACOG Free-Flow Speeds and Ultimate Capacity/Lane 14
 Table 13: Node Fields - PACOG Travel Model 15
 Table 14: Input Link Fields - PACOG Travel Model 16
 Table 15: Output Link Fields - PACOG Travel Model 17
 Table 16: Facility Type for Highway Links 17
 Table 17: Capacity Factors for Traffic Assignment 20
 Table 18: FHWA Truck Vehicle Classification 21
 Table 19: Truck Trip Generation Rates 22
 Table 20: Truck Trip Distribution Rates 22
 Table 21: SUT Validation Statistics 23
 Table 22: MUT Validation Statistics 24
 Table 23: Household Income Ranges 26
 Table 24: Home-Based Work Trip Production Rates 28
 Table 25: Home-Based Other Trip Production Rates 28
 Table 26: Home-Based Shop Trip Production Rates 28
 Table 27: Non-Home-Based Work-Related Trip Rates 28
 Table 28: Non-Home Based Other Related Trip Rates 29
 Table 29: Home-Based Elementary/Middle School Trip Production Rates 29
 Table 30: Home-Based High School Trip Production Rates 29
 Table 31: Home-Based College/University Trip Production Rates 29
 Table 32: Trip Attraction Rates 31
 Table 33: Work From Home (WFH) Percentages by Income Class Pueblo County 33
 Table 34: Trends in Average Daily Household Trips (NHTS) 36
 Table 35: Trends in Average Daily Household Trips (NHTS) 36
 Table 36: 2020 Total Productions and Attractions by Trip Purpose 37
 Table 37: Special Generators & Rates 39
 Table 38: Trip Distribution Parameters by Purpose 45
 Table 39: External Station 2020 Traffic Worksheet 46
 Table 40: Pueblo Transit System 48

Table 41: Pueblo Transit System.....	51
Table 42: PACOG Mode Choice Model Parameters	52
Table 43: PACOG Mode Choice Sensitivity Test Report.....	54
Table 44: Shared Ride Persons per Vehicle.....	54
Table 45: Time of Day Factors by Trip Purpose	55
Table 46: Auto Vehicle Trips by Time of Day.....	58
Table 47: Traffic Validation by Facility Type	63
Table 48: Traffic Validation by Volume Range.....	63
Table 49: Traffic Validation by Screenline	64

List of Acronyms

AADT	Average Annual Daily Traffic
ACS	American Community Survey
BPR	Bureau of Public Roads
CDOH	Colorado Department of Highways
CDOT	Colorado Department of Transportation
CDPHE	Colorado Department of Public Health & Environment
FTA	Federal Transit Administration
GHG	Greenhouse Gas
GIS	Geographic Information System
GPS	Global Positioning Satellite
GUI	Graphical User Interface
HCM	Highway Capacity Manual
HCS	Highway Capacity Software
HHTS	Household Travel Survey
LOS	Level of Service
LRP	Long Range Plan
MMT	Million Metric Tons
MPO	Metropolitan Planning Organization
MUT	Multi-Unit Trucks
NAICS	North American Industry Classification System
NCHRP	National Cooperative Highway Research Program
NHTS	National Household Travel Survey
OTIS	Online Traffic Information System
PACOG	Pueblo Area Council of Governments
PEL	Planning and Environmental Linkages
PRMSE	Percent Root Mean Square Error
QCEW	Quarterly Census of Employment & Wages
QRM	Quick Response Manual
RMSE	Root Mean Square Error
CO	Colorado State Highway
SUT	Single-Unit Trucks
TAZ	Traffic Analysis Zone
TCRP	Transit Cooperative Research Program
TIP	Transportation Improvement Plan
TLFD	Trip Length Frequency Distributions
TMIP	Travel Model Improvement Program
TRB	Transportation Research Board
USDOT	United States Department of Transportation
UTPS	Urban Transportation Planning System
VDF	Volume Delay Function
VHT	Vehicle Hours Traveled
VMT	Vehicle Miles Traveled

1 Introduction

1.1 The Need for Travel Demand Models

Since the passage of the 1962 Highway Act, urban areas within the United States have been required to base their transportation investments on a comprehensive, cooperative, and continuing transportation planning process. While various congressional acts have modified the specific legal requirements over the years, the essential requirement for a logical, rational transportation planning process remains a prerequisite for Federal transportation funding assistance, and in many areas, for state participation in funding transportation improvement projects.

One significant element of the transportation planning process involves projecting future transportation needs for the next 20 to 30 years. The most accepted method of projecting these future transportation needs, and for evaluating alternative improvement strategies to serve the projected travel demand needs, is using travel demand models. Travel demand models use socioeconomic land use data to estimate the demand for travel, and they use a coded representation of the transportation system to simulate the ability of the transportation system to serve the estimated travel demand.

When travel demand models are provided with projections of future socioeconomic land use data, they can be used to forecast the projected performance of alternative transportation improvement strategies. The reliability of these models is directly related to the likelihood that the input data correctly represents how land will develop in the future. The accuracy of traffic models is assessed by comparing the traffic volumes estimated by a model to observed traffic counts for a specific base year, for which socioeconomic land use data is also available. The development of a consistent base year database containing a transportation network and socioeconomic data is critical to the development and validation of a travel forecasting model.

1.2 Background of the PACOG Travel Model

The 2020 Pueblo Area Council of Governments (PACOG) travel demand model has profited from development and application in the last fifteen years. It has been updated and enhanced in this 2024 cycle in several important ways. These elements will be presented and discussed in this report, and include:

1. **Extended Model Forecast Horizon** – The new modeling system accommodates forecasts out to 2050, extending the model horizon an additional five years from the previous 2045 limit.
2. **Updated Observed Traffic Data** – The model integrates 2020 traffic count data by auto, Single Unit (SUT) and Multi Unit (MUT) truck.
3. **Zone System Revisions** – Zonal coverage was changed to match CDOT's Traffic Analysis Zone (TAZ) structure to provide better geographic resolution, and total consistency between the DOT and PACOG regarding base and forecast land use assumptions.
4. **Zonal Data Update** – Socioeconomic data was updated for population, households, median income, and group quarters (2020 Census). Employment data updated using the 2020 Quarterly Census of Employment & Wages (QCEW), data obtained from the Colorado Dept. of Labor & Employment, including employment point data (2021). Trip generation disaggregation values, and trip distribution targets utilize the 2010 Pueblo Front Range Household Survey data. An updated statewide travel survey is in progress.
5. **More Detailed Truck Vehicle Classes** – Previous versions of the model used Single Unit (SUT) and Multi Unit (MUT) trucks in trip generation and internal trip distribution, but then collapsed this category into a generic truck category in later model steps. This version carries SUT and MUT classes through all model steps and outputs.

6. **Addition of Transit Network** – Transit routes, stops, and service characteristics are included in the PACOG model for the first time. The additional transit network information is used to support transit skimming used in Mode Choice modeling and later in transit assignments. Roadway network detail and data attributes were expanded to support transit modeling as well.
7. **Added Mode Choice Modeling** – This is a new model component that was added to improve the model’s sensitivity to anticipated future scenarios. This component explicitly models individual choices related to traveling by auto and transit depending on trip purpose and characteristics of the journey to the destination location. Addition of the mode choice step significantly changed outputs and subsequent model steps related to Production-Attraction to Origin-Destination (PA-OD) conversion.
8. **Expanded Traffic Assignment** – The PACOG model provides traffic flow outputs for am and pm peak hours, the remaining 22 Off Peak hours, and daily totals. Outputs for vehicle classes are now split into Autos, SUT, and MUT. The process adds a Passenger Car Equivalent (PCE) methodology that accounts for the fact that trucks use more road capacity than autos. A daily transit route assignment is added as well, with transit outputs and reporting.
9. **User Interface, Analysis, and Reporting** – The PACOG model’s original reporting capabilities were updated to work with the new components/updates. Several new reporting outputs were added to summarize mode choice and transit assignment results. Additionally, the various roadway traffic assignment results can be summarized and processed for further greenhouse gas analysis. As part of the greenhouse gas analysis capabilities, the user interface allows users to apply some general assumption changes affecting travel demand/mode choice which can be applied in special model scenario runs. Reporting capability now includes customized Greenhouse Gas (GHG) reporting/output.

The PACOG travel model extent covers the entirety of Pueblo County which is almost 2,400 square miles. The base year is 2020. The validated 2020 base year model presented in this report captures the movements of over 169,000 persons in 67,000+ households. The entire PACOG model is implemented using Caliper Corporation’s TransCAD computer software package, Version 9.0.

The PACOG travel demand model has a long history. The original PACOG travel model was specified in a mainframe Urban Transportation Planning System (UTPS) platform and was developed and maintained by the then Colorado Department of Highways (CDOH). The model was transitioned to the MPO in 1984 after migration to the MinUTP software platform. The first survey-supported comprehensive update of the model by PACOG was completed in February 1994. Migration of the MinUTP model to the Colorado Department of Transportation’s preferred Caliper Corporation software, TransCAD, was completed in 2002 to support use for the New Pueblo Freeway Environmental Impact Statement. The 2014 model update continued with the TransCAD software platform, while integrating, within TransCAD, key functionality established in the 1994 work. In 2020, updating model parameters with a 2020 base year and recent household survey data paved the way for long range planning. The current 2024 update took a significant step forward in adding the first transit network with a supporting mode choice module. Additionally, the truck model was broadened to two classes of trucks and the model reporting capability expanded to produce data input files to Greenhouse Gas (GHG) models. The Covid-19 pandemic, spanning the years 2020 through 2022, has challenged the effort to prepare a representative 2020 base year. The PACOG travel demand model addressed these years by adjusting the work from home component of socioeconomic forecasting, and reviewing traffics counts from years 2020-2023 for identification of a “mid-point” base year best representing 2020. The result is a base year that captures 2020 while staying true to the changing travel patterns that emerged in the past four years.

During three decades of evolution, the PACOG model has continued to provide the agency with the capability to capture existing and future traffic for planning purposes as well as a tool for numerous traffic studies. The 2024 updated PACOG travel model extent with the revised zone system is shown below in **Figure 1**.

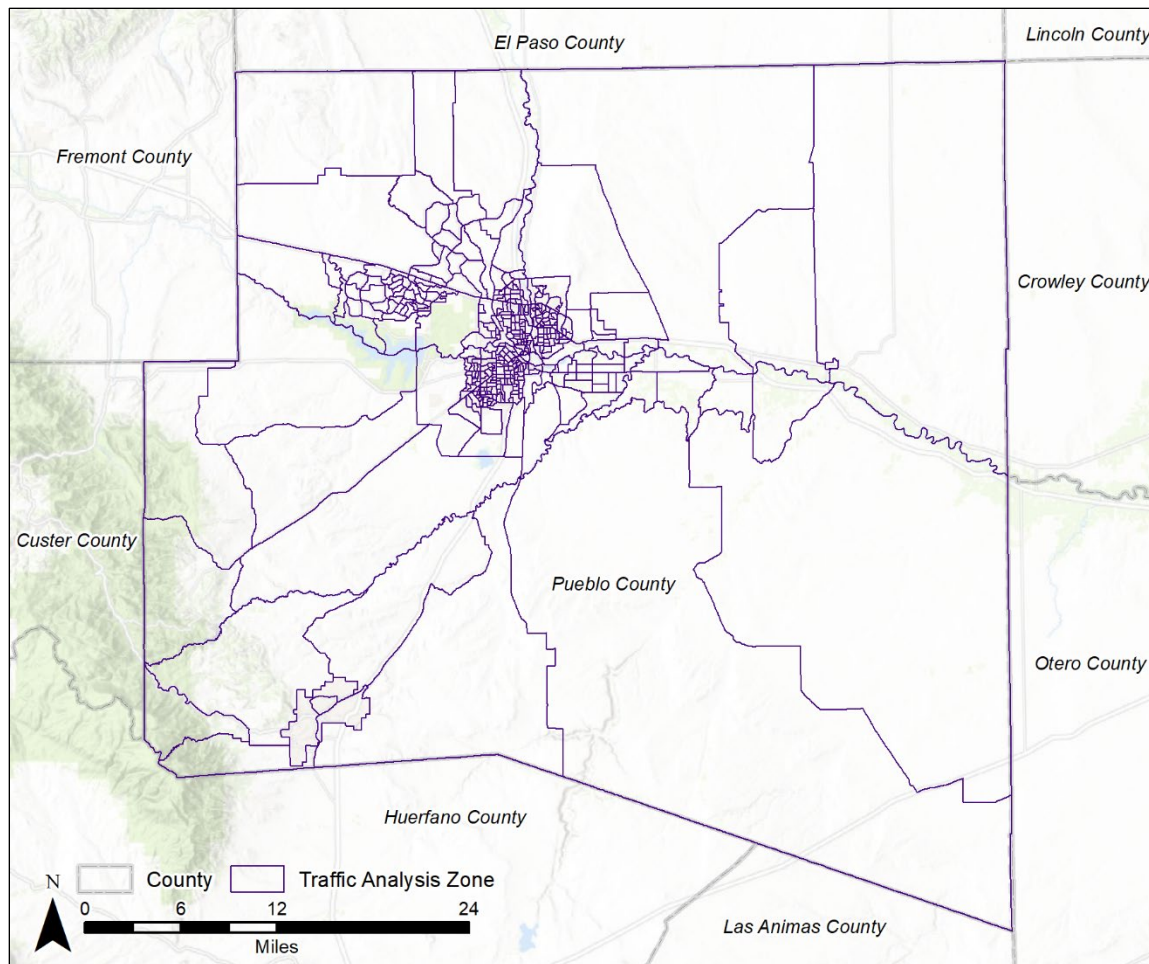

Figure 1: PACOG TAZ Layer and Travel Model Extent

1.3 The Traffic Forecasting Modeling Process

Standard four-step traffic forecasting models have the following basic components:

- Trip Generation
- Trip Distribution
- Mode Split
- Traffic Assignment

The PACOG travel model incorporates these four basic modeling components listed above to produce travel demand forecasts. The model contains three time periods. The am peak is 7:30 am - 8:30 am and the pm peak is 4:30-5:30 pm. The off-peak is composed of all other times of the day. These three time periods are summed to produce daily modeled traffic. A base year of 2020 and future year of 2050 are provided in the model. Intermediate years can be generated.

The process flow of the PACOG model will be described using the four-step model sequence. Information about data acquisition, processing and use will also be included in this report. The goal is to capture the details of the update and address issues related to their integration in the model.

2 Traffic Analysis Zones and Socioeconomic Data Development

2.1 Overview

The transportation demand side of the PACOG travel model was developed using an enhanced Traffic Analysis Zone (TAZ) layer covering the MPO extent, which is Pueblo County. This TAZ layer is consistent with the CDOT Statewide Travel Model. The 2024 update purposely adopted this TAZ system to streamline communication between the PACOG and statewide models.

2.2 Traffic Analysis Zones

A TAZ summary of zone type is presented in **Table 1**, and shows a total of 393 zones, including the eight external zones/stations.

Table 1: PACOG 2024 Traffic Analysis Zone Summary

Zone Type	TAZ ID Sequence	TAZ Count
Regular Traffic Analysis Zone	1 through 385	385
External Zones	401 through 408	8
Total		393

The Traffic Analysis Zone GIS database holds the master ID and the input attributes as shown in **Table 2**. The socioeconomic forecasts prepared for the model update are joined to this basic TAZ level layer during each model run.

Table 2: Zonal Attributes for the TAZ Layer

Attribute	Description
ID	PACOG Zone ID
Area	Area in Square Miles
County_ID	FIPS County ID
ST_ID	FIPS State ID
MPO	All TAZ are PACOG
Area_Type	Area Type (1 through 5)
Area_Type Description	Area Type (1=CBD, 2=Fringe, 3=Urban, 4=Suburban, 5=Rural)

2.3 Socioeconomic Data Development

2.3.1 Overview of Data Sources

Covid-19 Discussion

A wide array of data was used to update the TAZ layer for the PACOG model. An issue that needed discussion at the outset of the update was how to handle data selection for the year 2020 given the fluctuations that occurred during the Covid-19 pandemic. In every part of the country, reductions in traffic, employment, and travel in general occurred during the span of time when Covid-21 was active – in general years 2020 through 2022+. Data from these years needed to be reviewed and adapted thoughtfully. The challenge, then, was to assert a strategy for capturing a base year, call it **2020***, that would serve as a reasonable starting point for future year scenarios. On the observed traffic side, the decision was made to utilize 2022 and 2023 observed traffic to capture a realistic base year. On the household and population side, the recently released Census 2020¹ information on households and population was available, represented conditions in 2020, and was used; this information was verified,

¹ U.S. Census 2020 Data, <https://data.census.gov/>, accessed December 2023.

and adjusted, using the Colorado Department of Local Affairs² (DOLA) forecasts. PACOG 2020 households and population are also consistent with the CDOT statewide model. Employment base year and forecasts required both a point employment database from the CDOT Statewide Model, LODES employment summaries, DOLA summaries and data from the Colorado Quarterly Census of Employment & Wages (QCEW). Employment data was also verified, and adjusted, using the DOLA forecasts. PACOG staff also collaborated on the systematic collection and review of GIS files useful in model development; these included current streets, city boundaries, traffic counts, and transit route information. These GIS layers, combined with state and national data such as U.S. Census 2020 data and selected CDOT state travel model files, were used. **Table 3** shows the standard attributes developed from the various sources cited above for the 2020, 2030, 2040 and 2050 study years.

Table 3: Socioeconomic Attributes

Attribute	Description
TAZ	Traffic Analysis Zone ID
DISTRICT	District ID for Summary
AREA_TYPE	Area Type ID for Link Speed/Capacity Lookup
POP	Total Population
POPINHH	Population in Households
GQPOP	Population in Group Quarters
HH	Number of Households
INC	Median Income
HHSIZE	Average Household Size
TOTEMP	Total Employment
RETAIL	Retail Employment
BASIC	Basic Employment
SERVICE	Service Employment
GOVERNMENT	Government Employment
ELEM_ENROLL	Elementary School Enrollment
SEC_ENROLL	High School Enrollment
COLL_ENROLL	Collage Enrollment
ST	State (FIPS)
CNTY	County (FIPS)

2.3.2 Household & Population Data Development

The fundamental requirements for the socioeconomic data development are information on the number of households, the number of persons in households, the median household income, and the number of persons in group quarters. These attributes were available to the project from the 2020 U.S. Census with attributes available at the Census block, block group, or tract level, all of which can be aggregated into the PACOG TAZ geography. **Figure 2** shows the scale of the geographic aggregation process for block-to-TAZ; almost 6,000 Census blocks were used to populate the 385 PACOG TAZs.

² Colorado Department of Local Affairs (DOLA), <https://demography.dola.colorado.gov/>, accessed December 2023.

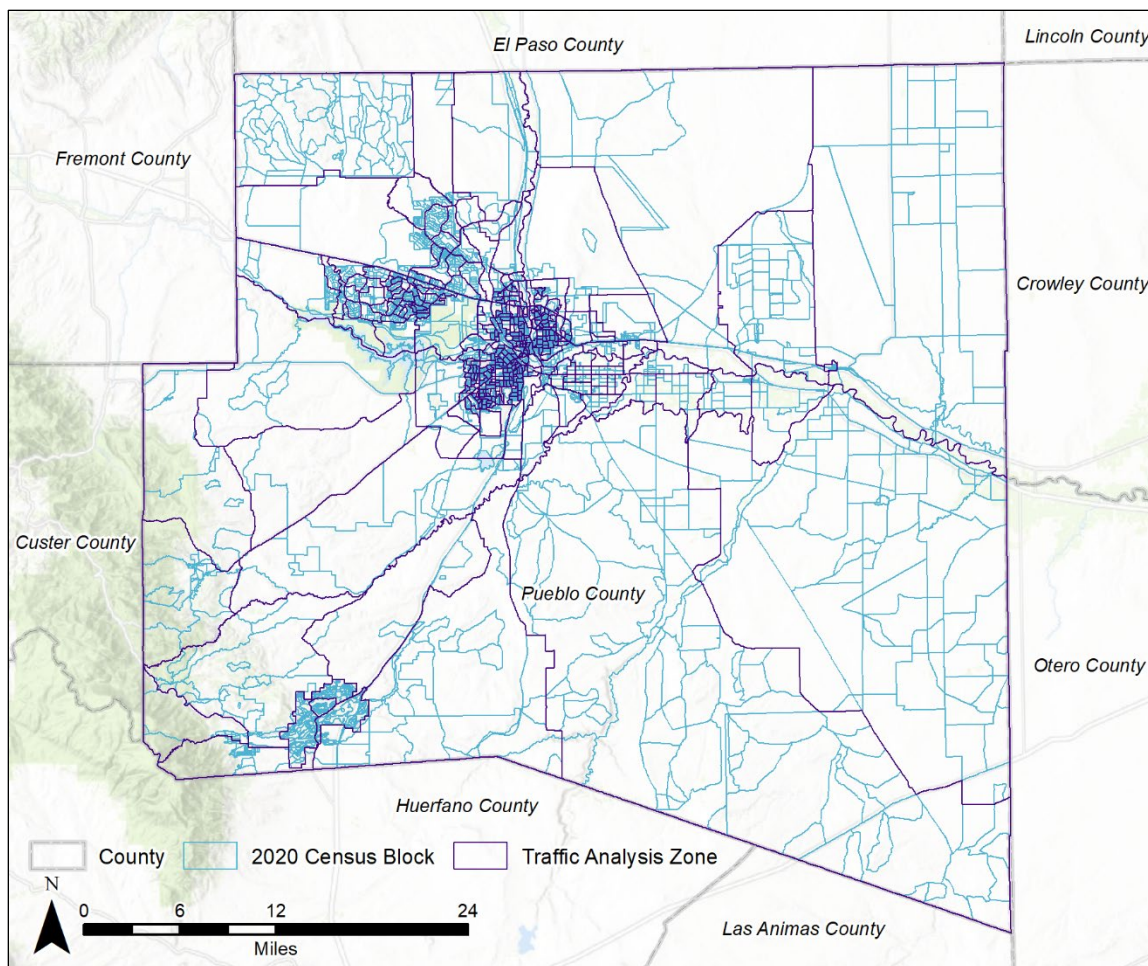

Figure 2: Census Block and PACOG TAZ Geography

Median income and group quarter location and population were derived from the Census tract layer. Group quarters facilities include college/university dormitories, health/rehab centers, assisted living, and correctional facilities. Persons in group quarters make up about 3% of the total population in Pueblo County. The Census values for group quarters were cross-checked with local maps and information and converted to PACOG TAZ geography. Forecasts utilized the DOLA totals for households, population, and jobs as control totals.

2.3.3 School Populations

School data is a small but key component of the travel model. School enrollment is required for trip generation. The enrollment numbers are required at three levels of academics:

- Kindergarten through 8th grade – 2020 enrollment was 16,990.
- High School – 2020 enrollment was 12,390.
- College/University – 2020 enrollment was 8,400.

The key data source used was the Colorado Public Health & Environment online school location GIS point file³. Both public and non-public schools in the K-12 level are included in this geodatabase. A secondary data collection investigation was conducted into “hybrid” schools, such as the GOAL

³ [CDPHE CDOE School Locations and District Office Locations | CDPHE CDOE School Locations and District Office Locations | Colorado Department of Public Health and Environment \(arcgis.com\)](#), accessed September 2023.

Academy system which combines online learning platforms with in-person support at student drop-in classrooms; GOAL serves about 5,900 students in Pueblo County. According to a GOAL administrator, on an average weekday 10-25% of the GOAL students report to a “bricks and mortar” location⁴. The GOAL Academy schools, and drop-in locations were identified, added to the geodatabase, after once adjustment by the percentage of students who are typically on-site. Forecasting for school attendance is done using the observed ratio of students to households. Colorado State University and Pueblo Community College enrollment is found on their websites.

2.3.4 Employment Data Development

The employment data task was to develop TAZ level employment by the four categories for all study years. The 2007 North American Industry Classification System⁵ (NAICS) was used to establish four categories of employment as shown in **Table 4**.

Table 4: PACOG Employment Categories by NAICS Code

Employment Category	NAICS Range
BASIC	<= 425120
RETAIL	441110 - 454390
SERVICE	481111 - 814110
GOVERNMENT	> 814110

The employment categories can be described as follows:

- **Basic** includes farming, forestry, fishing, mining, oil and gas extraction, major construction and manufacturing of all kinds including food, tobacco, lumber and paper, printing, chemicals, medical and optical goods, and wholesale trade.
- **Retail** includes the sale of building materials, hardware, garden, mobile homes, general merchandise, food, automotive, gasoline, clothing, furniture, eating and drinking places, and miscellaneous.
- **Government** includes public administration and other.
- **Service** includes information, finance and insurance, real estate, and rental services, professional and technical, educational, health care, entertainment, accommodation, transportation, and warehousing.

Data sources were the CDOT Statewide Model 2015 job establishments point file, the Colorado 2020 Quarterly Census of Employment & Wages (QCEW), LODES⁶ quarterly workforce indicators, and DOLA county level employment totals by category and by control totals. The CDOT point data was factored to 2020 DOLA totals then converted into the PACOG four employment categories to establish employment by classification at the zonal level. Growth rates by the employment categories were tied to the DOLA economic forecasts which include growth expectation by sector.⁷

⁴ Telephone call to GOAL regional administrative offices, September 2023.

⁵ [North American Industry Classification System \(NAICS\) U.S. Census Bureau](#), accessed November 2023.

⁶ Longitudinal Employer-Household Dynamics (LODES) data, <https://lehd.ces.census.gov/data/#odes>, accessed November 2023.

⁷ Labor Force Economic Forecasts, <https://gis.dola.colorado.gov/economy-labor-force/economic-forecasts/>, accessed December 2023.

2.3.5 Summary

In summary, DOLA control totals guided the socioeconomic development of the PACOG Model. Local, state, and national data provided input data, corroboration of values and control totals. **Table 5** shows the resulting totals for the four study years. **Table 6** shows the growth rates. Over the span of the 30-year forecast available, population grows 15%, households grow 20% and employment grows 17%.

Table 5: Colorado Department of Local Affairs (DOLA) Totals for Pueblo County

Socioeconomic Attribute	2020	2030	2040	2050
Population	168,311	178,217	188,514	193,446
Households	65,911	72,315	76,153	79,350
Employment	74,593	80,382	84,768	86,914

Table 6: Colorado Department of Local Affairs (DOLA) Growth Rates for Pueblo County

Socioeconomic Attribute	2020-2030	2030-2040	2040-2050	2020-2050
Population	6%	6%	3%	15%
Households	10%	5%	4%	20%
Employment	8%	5%	3%	17%

To summarize the socioeconomic data development step:

- Census 2020 provides a solid basic framework for the population, households, income, and group quarters model components.
- Colorado DOT statewide model employment point data is used as the primary input for employment data.
- County level growth by Colorado DOLA provides control totals for population, households, and employment.

2.4 Travel Model External Zones/Stations

Travel to and from locations outside of the PACOG region is captured using information from traffic flows located at the eight major external stations or portals to the region. In the current update, the previous all truck traffic vehicle class was expanded from all trucks to truck traffic by two size classifications, Single and Multi-Unit Trucks.

2.4.1 The Eight PACOG Model External Stations

The updated 2020 PACOG model captures eight external station or points as listed in **Table 7**. These points represent the major locations where highways link Pueblo County with all areas outside of the county. **Figure 3** shows the station locations.

Table 7: PACOG Model External Stations

External Stations	TAZ ID
Interstate 25 (North)	401
State Highway 96 (East)	402
US Highway 50 (East)	403
Interstate25 (South)	404
State Highway 165 (West)	405
State Highway 78 (West)	406
State Highway 96 (West)	407
US Highway 50 (West)	408

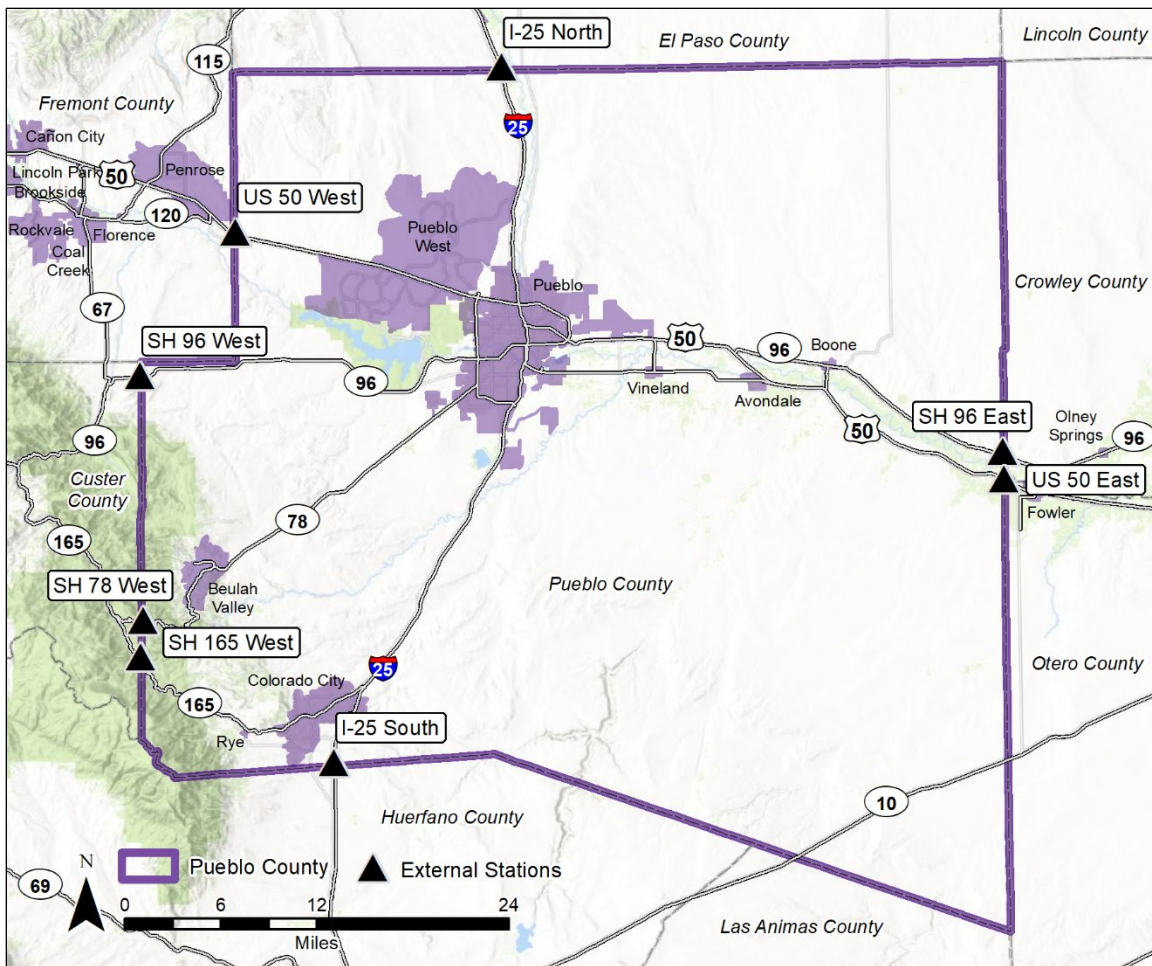

Figure 3: Location of PACOG External Stations

2.4.2 Estimating Base Year External Station Volumes

To estimate traffic volumes at the external stations for the 2020 base year, the following process was used:

- Available data for total traffic (AADT) and for SUT and MUT trucks were collected and tabulated. Analysis on the trend for observed traffic in Pueblo County was conducted to understand the impact of the Covid-19 pandemic with 2022-2023 traffic data selected for use.
- Through-traffic percentages were developed for each external-external pair to represent the external-external traffic share of total traffic at each external point.

A spreadsheet capturing the process was created for use in replicating the trip table approach for future years. The following data resources were used to develop the external station traffic volume estimates:

- 2022 Average Annual Daily Traffic (AADT) values were obtained from the Colorado Department of Transportation (CDOT) database, which is available online.⁸ The database provides historic and current traffic count data for CDOT facilities, and includes all highways represented by external stations in the PACOG model.
- Growth rates developed by CDOT.

⁸ <http://www.cdot.com> (Colorado Department of Transportation), accessed in 2023.

These data resources enabled the establishment of the 2020 estimated external station baseline counts summarized in **Table 8**. Truck percentages were also available for major highways from the CDOT database.

Table 8: PACOG Model External Station Observed Traffic

Route Location	External Zone	2-Way Traffic Autos	2-Way Traffic SUT	2-Way Traffic MUT
Interstate 25 (North)	401	26,000	1,000	3,000
State Highway 96 (East)	402	1,000	40	40
US Highway 50 (East)	403	3,000	140	370
Interstate 25 (South)	404	7,000	360	1,000
State Highway 165 (West)	405	1,000	30	30
State Highway 78 (West)	406	1,000	40	30
State Highway 96 (West)	407	1,000	30	60
US Highway 50 (West)	408	8,000	160	370

Source: Colorado DOT Online Transportation Information System (OTIS)

2.4.3 Estimating Future External Station Volumes

To estimate external traffic for future years, annual growth factors were obtained from CDOT. For consistency with statewide forecasts, 20-year growth factors from the CDOT web site were used to derive annual growth factors for each of the CDOT highways. First, a one-year, annual growth rate (F_1) was calculated for each CDOT 20-year facility growth factor (F_{20}) using a simple interest formulation, where: the annual growth (i) was calculated as the 20th root of the CDOT 20-year factor, minus 1 (e.g. $i = F_{20}^{(1/20)} - 1$ so for a 20-year factor F_{20} of 1.570, $i = 0.0228$). Using the calculated annual growth rate value, required growth factors could be calculated using: $F_n = (1+i)^n$.

Table 9 summarizes the calculated equivalent annual growth factors. These rates were used to prepare a 2050 traffic estimate for the external stations of the Pueblo model.

Table 9: External Station Future Year Traffic Counts Estimation

Route Location	External Zone	2-Way AADT	20-Yr Factor	Annual Factor	2-Way ADT
		2020	$F_{20} = (1+i)^{20}$	$F_A = (1+i)^1$	2050
Interstate 25 (North)	401	29,000	1.4	1.017	40,600
State Highway 96 (East)	402	1,000	1.52	1.0212	1,500
US Highway 50 (East)	403	3,700	1.08	1.0039	4,000
Interstate 25 (South)	404	8,100	1.31	1.0136	10,600
State Highway 165 (West)	405	800	1.29	1.0128	1,000
State Highway 78 (West)	406	1,000	1.32	1.014	1,300
State Highway 96 (West)	407	1,000	1.49	1.0201	1,500
US Highway 50 (West)	408	8,100	1.35	1.0151	10,900
Total		56,120			71,500

2.5 Area Type

Five distinct area types were updated from the legacy Pueblo model and adjusted to fit the revised 2020 zone system. A review of the model documentation shows that area type is used in the link speed assumptions and the trip distribution step. The area type designation is related to population/employment density as well as to the density of the street grid. Central Business District (CBD) zones have a dense street grid compared to outlying areas and feature significant walkability. CBD Outlying area type maintains some of the features of CBD, while being slightly less dense. Urban areas have a regular street grid and feature less walkability than CBD and CBD Outlying. The suburban and rural area types move toward a street grid and design most consistent with the auto mode.

Table 10 shows the number of TAZs by area type in the Pueblo model. **Figure 4** shows the area type in plot form with **Figure 5** illustrating a close-up of this attribute in the urban area. The area type has been permanently saved on the TAZ and link layer for use in the model update.

Table 10: Number of TAZs by Area Type

Area Type	Number of TAZs
Central Business District (CBD)	10
Outlying CBD	16
Urban	109
Suburban	217
Rural	33
Total	385

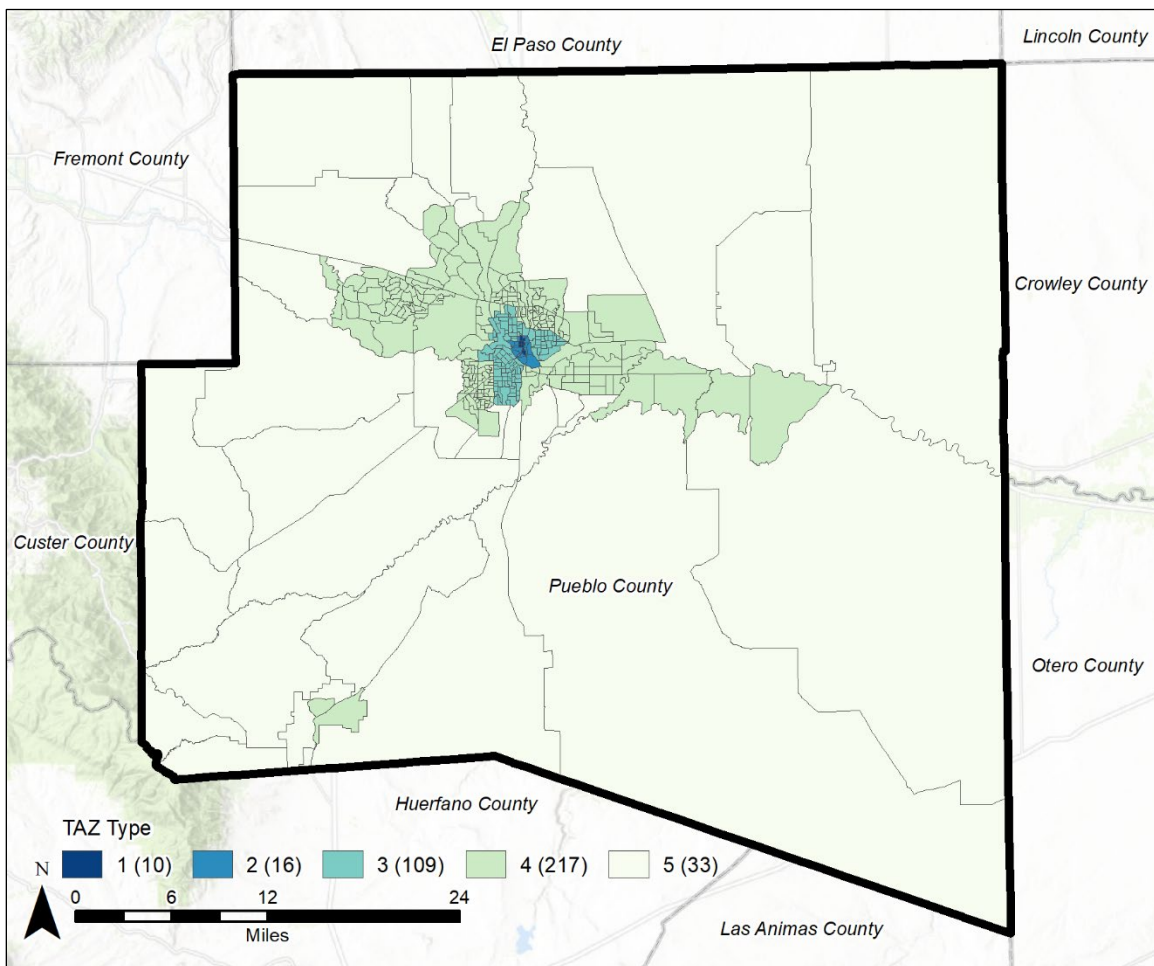

Figure 4: Area Type

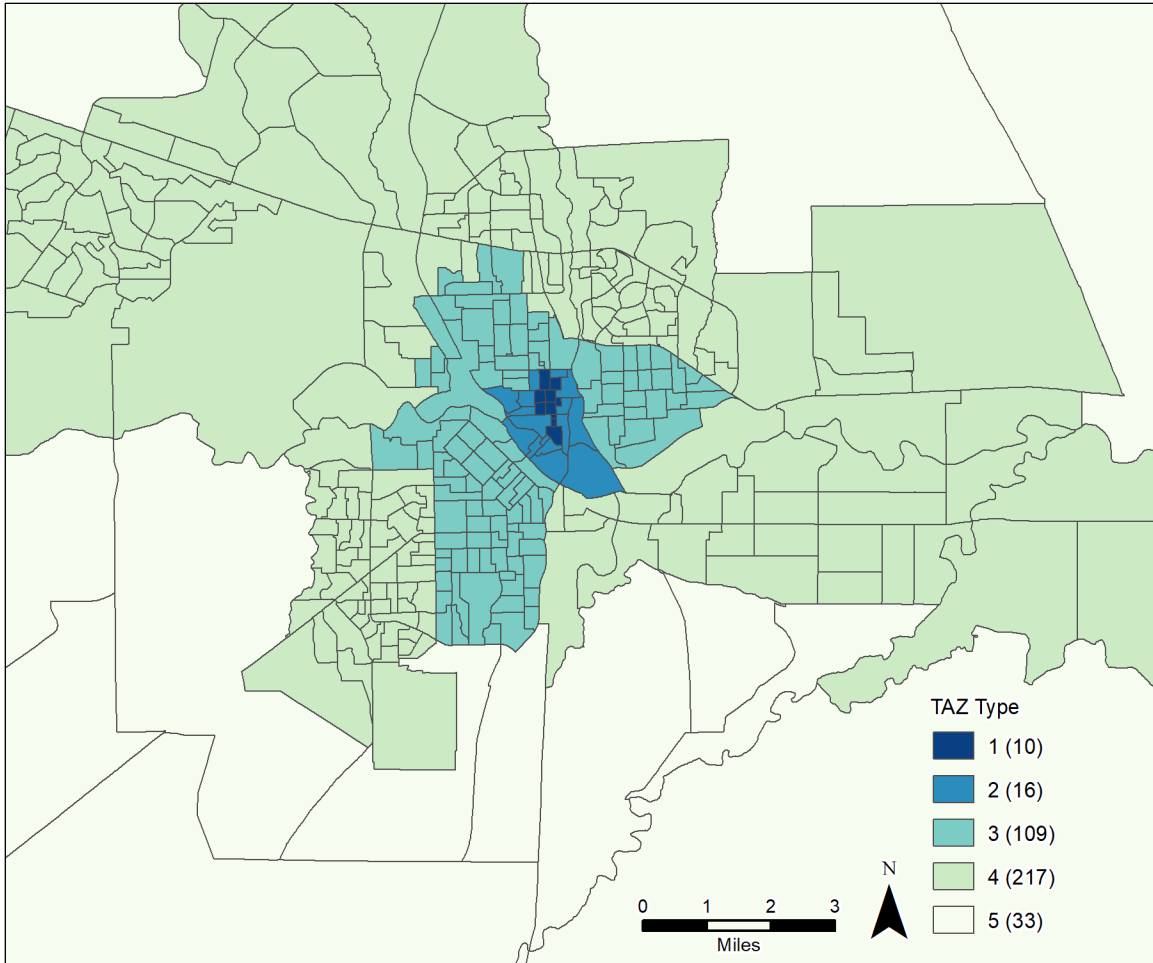

Figure 5: Area Type (Inset)

3 Highway Network Update

3.1 Background

The 2020 PACOG network model was updated using the TransCAD software Version 9.0, a product of Caliper Corporation. There are three highway network building blocks:

- **Nodes** are elements that describe the position of intersections or shape points on roadway networks.
- **Links** are network model segments that connect the nodes, represent roadways, and have attributes including direction, speed, capacity, and functional classification.
- **Centroid Connectors** are links that connect the zones to the network. They represent the distance to be covered between a zone's center of gravity (the center of trip generating and attracting activity) and the model links serving that zone.

3.2 Base Year Network Development

The 2020 highway network from the travel model update and long-range plan work of 2020 was identified and updated for the current model. This development required review and editing of the previous network to capture the changes in the region over the past four years. Network verification was conducted using aerial imagery and street layer geospatial data. The most extensive revisions were needed to implement the expanded traffic analysis zones and the addition of a transit network. Legacy centroid connectors were removed, and new connectors were put in place to serve the updated traffic analysis zones and to capture bus stop locations. Link locations and attributes were also verified, new roadways and widening projects completed in recent years were added. Traffic counts representing 2020 were added. Finally, network connectivity was tested.

3.3 Development of Link Speeds and Lane Capacities

PACOG travel models network use Level of Service (LOS) C capacities for roadway facilities. This conforms to an approach that constrains traffic volumes to desired design level of service volumes. National Academy of Sciences Transportation Research Board (TRB) guidance recommends that travel demand model capacity settings be set at "ultimate capacity," the point at which congestion-induced delays would result in diversion of traffic to alternate routes, and that applicable capacity assumptions should be developed in accordance with procedures detailed by the current Highway Capacity Manual (HCM) or from the Highway Capacity Software (HCS) or similar analysis tool.

A speed capacity look-up table was used to transfer the Level of Service associated capacities and link speeds to the PACOG highway network. The look-up table maps the appropriate capacity assumption to each functional classification in the model network. The capacity of centroid connectors is typically assumed to be very large, since these links represent the numerous ways that travelers within a zone can reach the larger highway network. **Table 11** shows the seven functional classes of highway links used in the PACOG travel model.

Table 11: PACOG Link Functional Class

Facility Type (Fac_Type)	Description
1	Interstate
2	Expressway
3	Principal Arterial
4	Minor Arterial
5	Collector
6	Ramp
7	Centroid Connectors

Speed-capacity assumptions for the newly updated PACOG travel model were developed through review and iterative testing of speed and capacities used in the four most recent legacy model versions, as well as a LOS C, HCM-based assumption set. The final capacity assumptions, shown in the rightmost column of **Table 12**, are somewhat lower than standard HCS values, adjusted to better reflect local conditions. These values and the associated travel speeds are also consistent with assumptions used for earlier PACOG travel model versions that were calibrated to local conditions. These values are also supported by literature research including the Highway Capacity Manual 2010 and comparison to peer model settings. Reduced congested speeds, used in the first iteration to “seed” the travel time skims, were implemented by the 1994 legacy model, and later abandoned. This option is retained, though not implemented in the current model update.

Table 12: PACOG Free-Flow Speeds and Ultimate Capacity/Lane

Link Type	Area Type Description	Area Type	Facility Type	Congested Speed	Free Flow Speed	Capacity
11	CBD	1	1	55	55	1600
12		1	2	22	22	650
13		1	3	17	17	500
14		1	4	17	17	450
15		1	5	15	15	450
16		1	6	10	10	350
17		1	7	15	15	1200
21	CBD Outlying	2	1	48	48	1700
22		2	2	25	25	700
23		2	3	28	28	600
24		2	4	28	28	500
25		2	5	25	25	500
26		2	6	10	10	350
27		2	7	15	15	1200
31	Urban	3	1	50	50	1900
32		3	2	35	35	900
33		3	3	30	30	750
34		3	4	30	30	650
35		3	5	25	25	650
36		3	6	20	20	400
37		3	7	15	15	1500
41	Suburban	4	1	55	55	1900
42		4	2	40	40	900
43		4	3	38	38	750
44		4	4	35	35	600
45		4	5	30	30	600
46		4	6	15	15	400
47		4	7	15	15	1500
51	Rural	5	1	60	60	1900
52		5	2	50	50	800
53		5	3	46	46	650
54		5	4	45	45	600
55		5	5	35	35	600
56		5	6	20	20	450
57		5	7	15	15	1500

3.4 Node Attributes

The node layer supports the links and serves as the source of the centroid and zone ID. **Table 13** shows the node attributes. Note that any nodes at which turns are to be saved during assignment can be selected prior to the network assignment using “Turn_Flag=1”.

Table 13: Node Fields - PACOG Travel Model

Name	Type	Description
ID	Integer	TransCAD Internal Node ID
Longitude	Integer	Node Latitude
Latitude	Integer	Node Longitude
Elevation	Real	Node Elevation (not active)
Centroids	Integer	1 if the Node is a Centroid
Turn_flag	Integer	1 if the Node Turn movement is to be saved during assignment

3.5 Link Attributes

The following revisions were done to the network during review and re-dimensioning:

- I-25/Dillon Drive area was reviewed, and connector links added to capture traffic prior to Dillon Drive entering the intersection.
- Nodes were added where bus stops are present (transit network functionality).
- A review of the functional class and number of lanes was performed.
- Traffic counts for AADT, SUT and MUT were added to represent 2020.

Key input link attributes are shown in **Table 14**. Note that inputs for the three time periods, am, pm and off-peak link segment inputs are held in this single network. The input network is found in the PACOG model input folder with a name keyed to the study year; an example is “2020_BaseNetwork.DBD”

Table 14: Input Link Fields - PACOG Travel Model

	Name	Type	Description
Input	ID	Integer	TransCAD Internal Node ID
	Dir	Integer	Direction with 0=two-way and 1 or -1 = one-way
	Length	Real	Link Length in Miles
	TYPE	Integer	Link Type (Area/Functional Class)
	Distance	Real	Link Length in Miles
	Mode	Integer	1=Non-Centroid Connector link; 2= Centroid Connector Link
	Area_Type	Integer	Area Type
	Fac_Type	Integer	Facility Type
	AB_Num_LANES	Integer	Number of Lanes (by direction)
	BA_Num_LANES	Integer	Number of Lanes (by direction)
	AB_FFSpeed	Integer	Free Flow Speed (by direction)
	BA_FFSpeed	Integer	Free Flow Speed (by direction)
	AB_FFTime	Integer	Free Flow Travel Time (by direction)
	BA_FFTime	Integer	Free Flow Travel Time (by direction)
	AB_CongSpeed	Integer	Congested Speed (by direction)
	BA_CongSpeed	Integer	Congested Speed (by direction)
	AB_CongTime	Integer	Congested Travel Time (by direction)
	BA_CongTime	Integer	Congested Travel Time (by direction)
	AB_AM_CAP	Integer	AM Link Capacity (By Direction)
	BA_AM_CAP	Integer	AM Link Capacity (By Direction)
	AB_PM_CAP	Integer	PM Link Capacity (By Direction)
	BA_PM_CAP	Integer	PM Link Capacity (By Direction)
	AB_OP_CAP	Integer	Off Peak Link Capacity (By Direction)
	BA_OP_CAP	Integer	Off Peak Link Capacity (By Direction)
	AB_NAME	Integer	Street Name
	BA_NAME	Integer	Street Name
	AB_DIR	Integer	AB Direction
	BA_DIR	Integer	BA Direction
	AB_DES	Integer	Street Description
	BA_DES	Integer	Street Description
	Count_Year	Character	Street Name
	AB_Daily_Count	Real	AB Direction ADT Count
	BA_Daily_Count		BA Direction ADT Count
	TwoWay_Count		Two-Way ADT Count
	Source		Character
	Year	Integer	Year of Count Collection
	AB_SUT_2022	Integer	Single Unit Truck Count (by direction)
	BA_SUT_2022	Integer	Single Unit Truck Count (by direction)
	AB_MUT_2022	Integer	Multi-Unit Truck Count (by direction)
	BA_MUT_2022	Integer	Multi-Unit Truck Count (by direction)
WalkMode	Integer	All set to value 3	
WalkT	Real	Walk Time: Length/(3/60) assuming walk at 3 mph	
IVTT	Real	In Vehicle Time for Bus: Length/(14/60) assuming bus speed at 14 mph	

Once the network is used in a model scenario, it emerges as a “loaded network,” a GIS ready network with daily assigned traffic as attributes. An example is “LoadedDailyNetwork_2020.DBD. Its attributes are shown in **Table 15**.

Table 15: Output Link Fields - PACOG Travel Model

Output	Name	Type	Description
	AB_AM_Flow	Real	1 hour AM period Total Traffic (by direction)
	BA_AM_Flow	Real	1 hour AM period Total Traffic (by direction)
	AB_OP_Flow	Real	22-hour off-peak period Total Traffic (by direction)
	BA_OP_Flow	Real	22-hour off-peak period Total Traffic (by direction)
	AB_PM_Flow	Real	1 hour PM period Total Traffic (by direction)
	BA_PM_Flow	Real	1 hour PM period Total Traffic (by direction)
	AB_Daily_Flow	Real	Daily Traffic (by direction)
	BA_Daily_Flow	Real	Daily Traffic (by direction)
	TwoWay_Daily	Real	Total Daily Traffic
	VMT_Daily	Real	Daily Vehicle Miles Traveled
	Vol_Range	Integer	Volume Range
	AB_AM_VC	Real	Volume to Capacity Value for AM period (by direction)
	BA_AM_VC	Real	Volume to Capacity Value for AM period (by direction)
	AB_OP_VC	Real	Volume to Capacity Value for off-peak period (by direction)
	BA_OP_VC	Real	Volume to Capacity Value for off-peak period (by direction)
	AB_PM_VC	Real	Volume to Capacity Value for PM period (by direction)
	BA_PM_VC	Real	Volume to Capacity Value for PM period (by direction)
	AB_DAILY_VC	Real	Volume to Capacity Value for Daily (by direction)
BA_DAILY_VC	Real	Volume to Capacity Value for Daily (by direction)	

Table 16 shows the link facility type (Fac_Type) used in the mapping. **Figure 6** shows the 2020 PACOG Highway Network with **Figure 7** showing a close-up of the urban area. The link attribute “Facility Type” is used to differentiate the links.

Table 16: Facility Type for Highway Links

Facility Type (Fac_Type)	Description
1	Interstate
2	Expressway
3	Principal Arterial
4	Minor Arterial
5	Collector
6	Ramp
7	Centroid Connectors

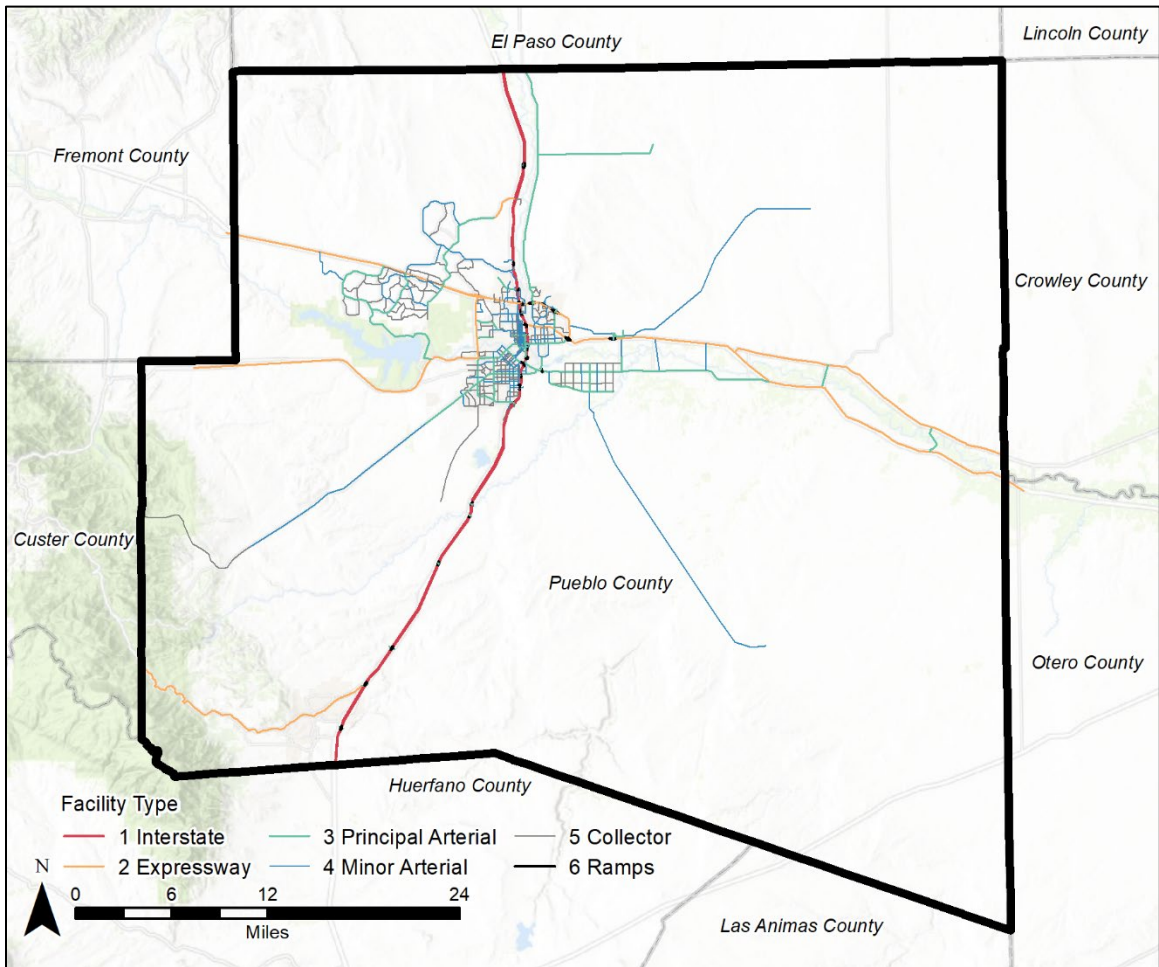

Figure 6: 2020 Link Facility Type

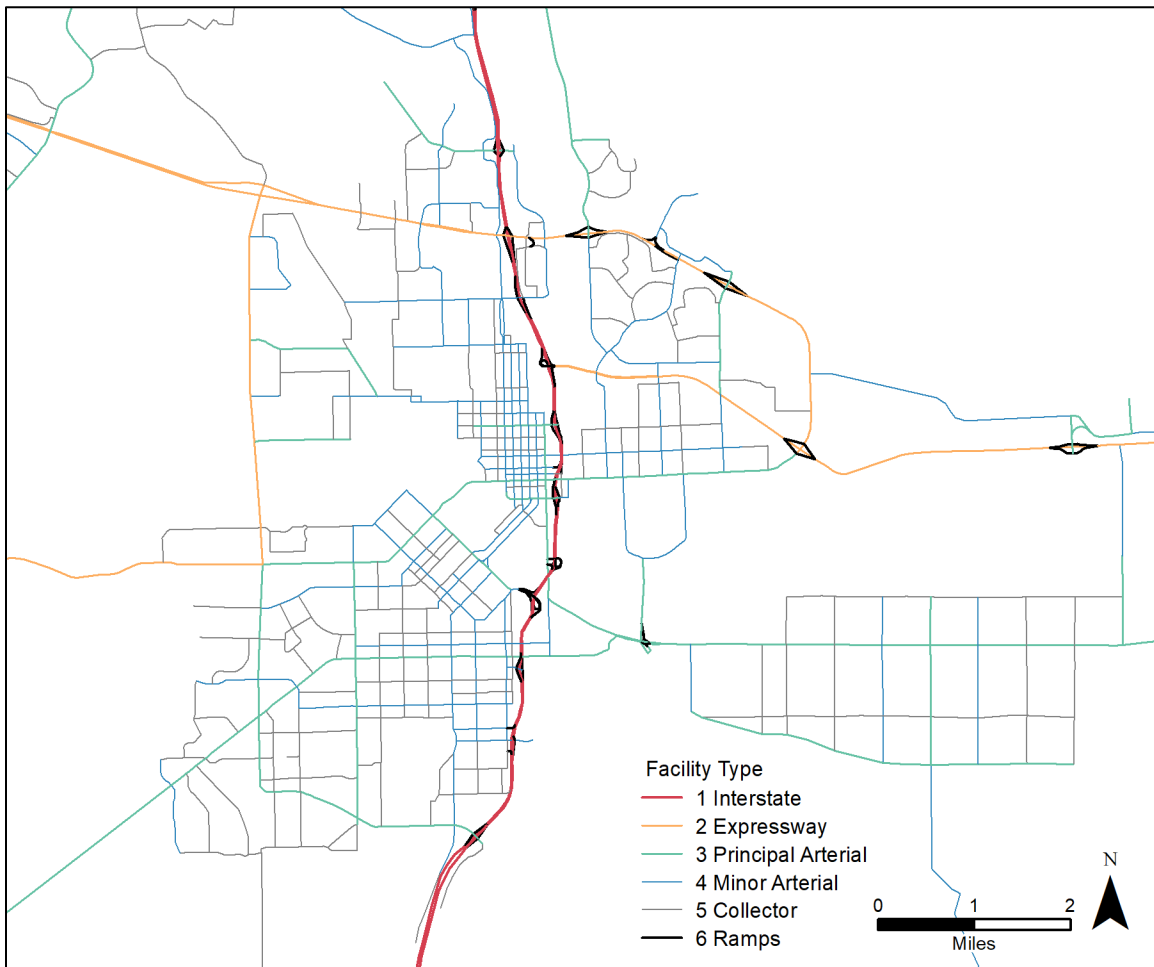

Figure 7: 2020 Link Facility Type Inset

3.6 Time of Day Capacity Assumptions

The PACOG Travel Demand Model contains three time periods. These are the am peak (7:30-8:30 am), the pm peak (4:30-5:30 pm) and the off-peak which is composed of the sum of all other times of the day. The link segment capacity multiplier for each of the two peak periods is set as “1” since they each represent one hour. During network building the “1” is multiplied by the lane capacity and the number of lanes to calculate the carrying capacity of the link segment during that one hour. The off-peak period is composed of all remaining hours spread throughout the day including late morning, midday, afternoon, evening and overnight. It will naturally have a larger capacity multiplier than do each of the peak hours. Since the off-peak period traffic is not evenly spread over the 22 off-peak hours, the network factor is not 22. Rather a factor of 11 has been determined to represent the traffic flow that takes place within the off-peak period. The factor of 11 was estimated based on an analysis of the time-of-day of travel data summarized from the 2010 Front Range Household Survey. **Table 17** shows the am, pm, and off-peak capacity factors used for the traffic assignments. The sum of traffic from the three time-period assignments adds up to daily traffic.

Table 17: Capacity Factors for Traffic Assignment

Period Name	Length (Hours)	Capacity Factor
AM Peak	1	1
PM Peak	1	1
Off Peak	22	11

3.7 Turn Movements and Prohibitions/Penalties

The PACOG Travel Model application of TransCAD software has the capability to conduct analysis reporting on turning movements.

Turn Movements – Turn movements are activated by placing a “1” in the “Turn_Flag” attribute of the network node file. All nodes with this setting will be selected during each of the three time of day model runs. During assignment all turn movements from the selected nodes will be exported to a “Turn Movement” assignment output file.

Turn Prohibitions & Penalties – Turn prohibitions and penalties (in minutes) are available for the PACOG travel model. A file called “turnpen.dbf” in the parameter folder can be activated. In model application the turn prohibitors are listed in a file that TransCAD reads during the assignment process. Activating turn movements can be of value in conducting corridor traffic studies or similar small-scale efforts where turn delay data is available. At the regional level there is risk in activating some turns but not all as this approach can perturb regional patterns of traffic. Global settings are activated in the current model to disallow U-turns throughout the region.

4 Truck Model

The PACOG travel model features a three-step truck model that expands upon the previous one truck class model by generating, distributing, and assigning two classes of truck.

4.1 Truck Model Approach

The truck model is framed using CDOT’s vehicle classification definition⁹ which is drawn from the FHWA vehicle classification scheme. The FHWA approach is shown in **Table 18** and in **Figure 8**. There are two truck classes in the PACOG model:

- Single Unit Trucks - Vehicles larger than pickup trucks built on a single chassis and consistent with FHWA Classes 4-7.
- Combination or Multi Unit Trucks – trucks with 3 or more axles-single trailer or multiple trailers and consistent with FHWA Classes 8-13.

The TMIP Quick Response¹⁰ modeling approach was utilized as a starting point. Adjustment to Pueblo conditions was required, with both truck trip generation and distribution rates adjusted using feedback from the assignment process. SUTs were set to 1.5 and MUT to 2.5 Passenger Car Equivalents (PCE) during assignment. The Colorado DOT provided sufficient observed truck data to validate the PACOG MPO model by SUT and MUT classes. The observed truck data consists of 132 locations delivering 322 directional truck counts in the PACOG region.

Table 18: FHWA Truck Vehicle Classification

PACOG Vehicle Classification	FHWA ID	Description
Passenger Vehicles	Class 1	Motorcycles, Autos and Trucks
	Class 2	
	Class 3	
Single-Units	Class 4	Buses
	Class 5	Two Axle, Six Tire, Single Unit Trucks
	Class 6	Three Axle Single Unit Trucks
	Class 7	Four or More Axle Single Unit Trucks
Multi-Units	Class 8	Four or Fewer Axle Single Trailer Trucks
	Class 9	Five Axle Single Trailer Trucks
	Class 10	Six or More Axle Single Trailer Trucks
	Class 11	Five or fewer Axle Multi Trailer Trucks
	Class 12	Six Axle Multi Trailer Trucks
	Class 13	Seven or More Axle Multi Trailer Trucks

⁹ CDOT Catalog Search / Glossary, <https://dtdapps.coloradodot.info/otis/catalog>, accessed November 2023.

¹⁰ Source: NCFRP Report 31: Incorporating Truck Analysis into the Highway Capacity Manual (2014), accessed November 2023.

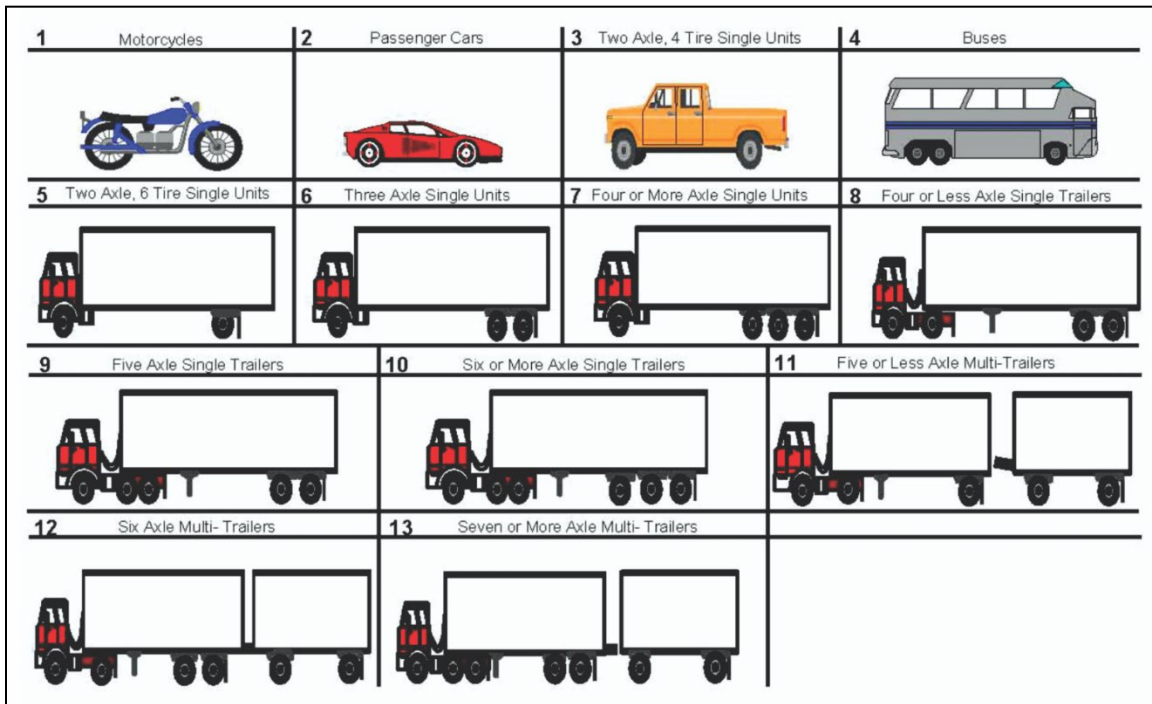

Figure 8: FHWA Truck Vehicle Classification

4.2 Truck Trip Generation and Distribution

Two sizes of trucks are generated using attraction rates only. These rates are written to the production side of the distribution model. Through truck trips are to be developed in a separate step. The general concepts used in the TMIP approach were utilized for this 2020 update with input adjustments for local conditions. Truck trip generation rates and distribution values are shown in Table 19 and Table 20.

Table 19: Truck Trip Generation Rates

Purpose	HH	Retail	Basic	Service	Government	Elem_Enroll	Sec_Enroll	Colleg_Enroll
SUT	0.042	0.100	0.024	0.190	0.090	0.030	0.030	0.030
MUT	0.022	0.080	0.015	0.013	0.009	0.010	0.010	0.010

Table 20: Truck Trip Distribution Rates

Purpose	Alpha	Beta	Gamma
SUT	--	--	0.227
MUT	--	--	0.048

4.3 Truck Model Validation

The two classes of trucks, SUT and MUT, were subjected to validation tests.

Single Unit Trucks had 322 directional counts available for validation. At the daily level, the count and model flow volume for these trucks differed by 1.6%. The Root Mean Square Error (RMSE) was 53. The scatterplot shows an R-squared of 75% with a good fit between modeled and observed SUTs as shown by the adherence to the diagonal.

Table 21: SUT Validation Statistics

Truck Class	Type ID	# of Obs.	RMSE	RelRMSE	Sum of Counts	Sum of Flows	% Difference
Single Unit	SUT	322	114.66	52.97	69,706	70,852	1.6%

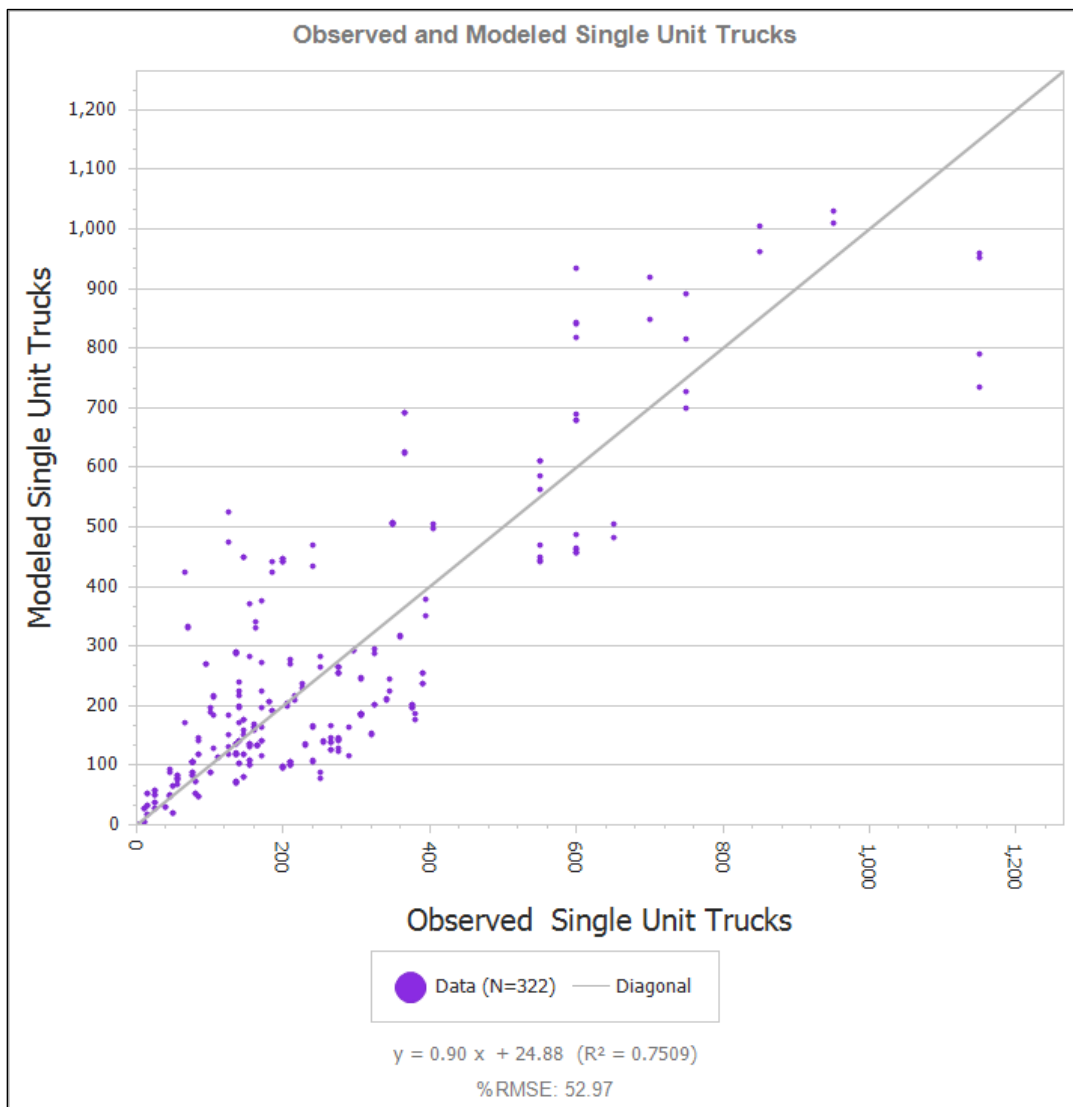

Figure 9: SUT Validation Scatterplot

Multi-Unit Trucks had 322 directional counts available for validation. At the daily level, the count and model flow volume for these trucks differed by 2.8%. The Root Mean Square Error (RMSE) was 40. The scatterplot shows an R-squared of 92% with a good fit of modeled to observed MUTs as shown by the adherence to the diagonal.

Table 22: MUT Validation Statistics

Truck Class	Type ID	# of Obs.	RMSE	RelRMSE	Sum of Counts	Sum of Flows	% Difference
Multi-Unit	MUT	322	90.84	39.61	73,849	75,921	2.8%

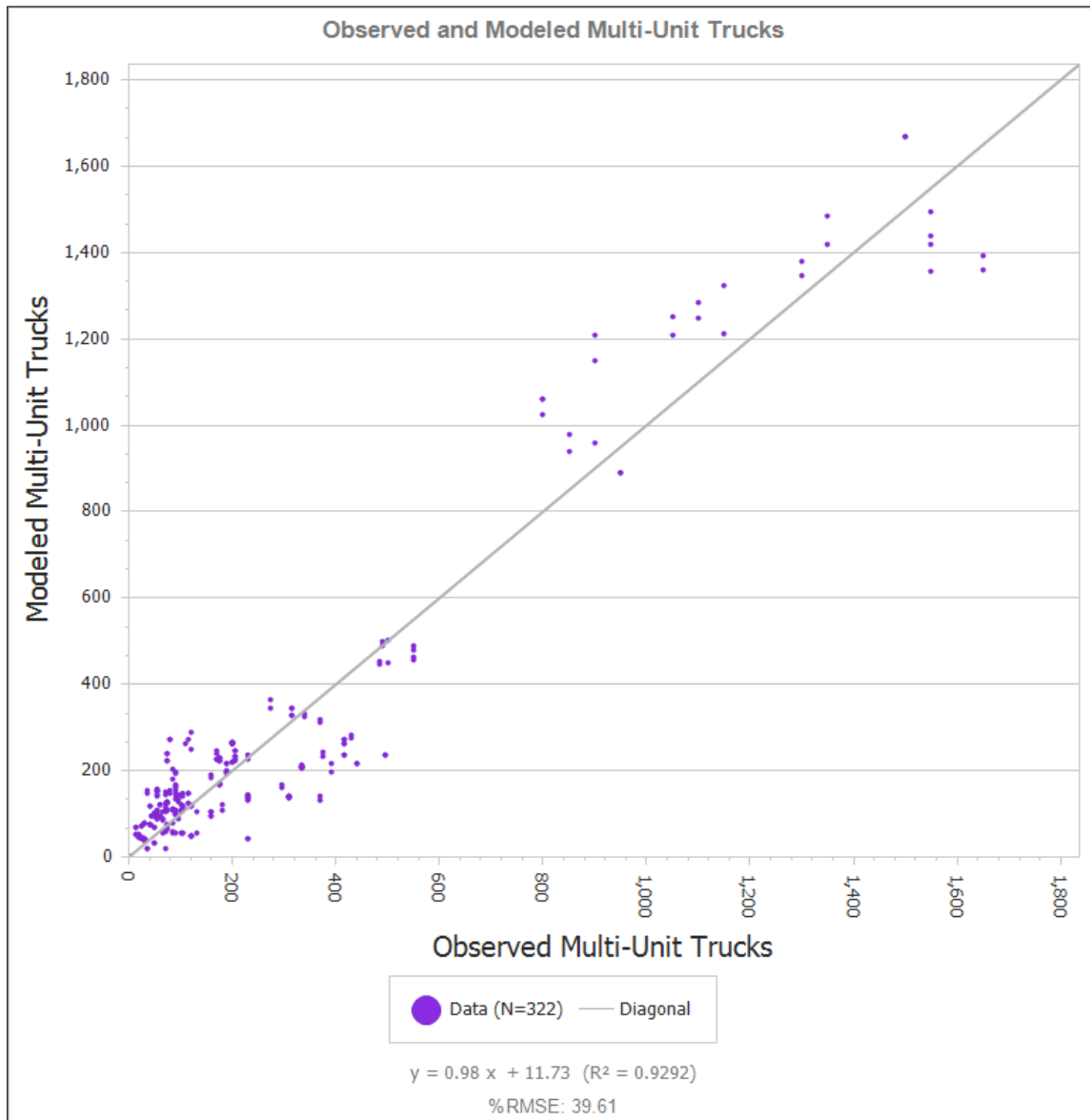

Figure 10: MUT Validation Scatterplot

5 Trip Generation

The first step in the four-step travel demand model development process is accomplished by the trip generation models. Trip generation is composed of two fundamental components: 1) household trip rate

development and application, and 2) special generator approach. Household trip generation steps include socioeconomic disaggregation, trip production and attraction models, and external trip models, all of which are developed using a household travel survey. Special generator models are built for facilities whose traffic is not driven by household-based trip generation. In the Pueblo region, special generator approaches have been developed for recreational and tourist destinations. These facilities use data and information, such as annual visitors, to estimate trip-making behavior.

5.1 Overview of Components

5.1.1 Household Trip Generation

Household trip generation includes procedures to estimate the travel demand associated with specific socioeconomic characteristics and land use activities. The goal of the trip generation model is to estimate trip productions and trip attractions for use in the model steps that follow. There are four key components of trip generation:

- **Socioeconomic Disaggregation** – These models begin with aggregate data such as the total number of households and the mean household size per TAZ. The data is then disaggregated to obtain the finer level detail needed to generate trips by cross-classification. This step is conducted within the TransCAD trip generation cross-classification module by four income and five household size categories.
- **Trip Production Models** – These models estimate trip productions on a TAZ level. Productions are typically a function of population or number of households along with a measure of wealth such as income or auto ownership. In the Pueblo travel demand model, household size and income level were used to produce trip rates for eight purposes.
- **Trip Attraction Models** – These models estimate trip attractions on a TAZ level. Attractions are typically a function of socioeconomic activity, households, employment by type, or school enrollment but they may also be land-use based such as retail square feet, open space or parks, gross floor area of manufacturing, or other.
- **External Trip Models** – These models estimate the number of trips that enter/exit the study area at the external stations of the travel model. Both external-internal/internal-external and external-external trips are estimated for Pueblo.

5.1.2 Truck Trip Generation

Trucks are generated in the Pueblo model using a modified Quick Response Manual (QRM) approach. Both Single Unit Trucks (SUTs) and Multi Unit Trucks (MUTs) are generated and distributed.

5.1.3 Special Trip Generators

In travel demand modeling, separate trip attraction models are recommended for special generators within a region, such as airports and other facilities that produce significant traffic that is not predicted by the household and employment information. Trip rates for these facilities can be developed by adapting national or ITE¹¹ rates, but are best based upon specific local surveys, data and counts if this data is available. For the Pueblo travel model a combination of both methodologies was used. In the Pueblo area, special generators include:

- Colleges and Universities
- Recreational Generators
- Tourist Destinations
- The Pueblo Airport (PUB)

¹¹ Institute of Transportation Engineers, Trip Generation, 9th Edition, ITE, 2012.

5.2 Household Socioeconomic Disaggregation

The PACOG travel model uses the number of households stratified by household size and income group as the primary independent variables for estimating trip productions. The stratification is applied at the TAZ level.

5.2.1 Household Income Categories

The four income categories used in trip generation were established to stratify the model's households. Income affects the rate of trip making and the stratification captures this differential. The income categories were stratified using the 2021 American Community Survey data. **Table 23** lists the income categories with the number of households in each category as well as the percentage each category is of the total.

Table 23: Household Income Ranges

Income Level	Number of Households	% of Total	Income Category
less than \$41,999	15,817	24%	1
\$41,999 to \$49,999	16,901	25%	2
\$50,000 to \$65,999	15,989	24%	3
over \$65,999	17,735	27%	4
Total	66,442	100%	

5.2.2 Household Trip Production Model

The production model selected for Pueblo is a two-way cross classification model which estimates motorized person trip rates by household stratified by two independent variables: household size and household income.

5.2.3 Trip Purposes

Fundamental to the trip generation model is an understanding of trip purpose. People travel for a multitude of reasons—work, shopping, recreation, school, doctor, post office, and dropping or picking up passengers. Because each distinct reason for trip making cannot be included in the trip generation model, a set of major trip purposes were established and used in the PACOG travel model to serve the year 2020. These purposes were adapted from the previous PACOG model which used the 2010 Colorado Front Range Household Survey. An updated Household Survey is expected to be completed in 2025 at which time these rates will be available for a model update. Eight final trip purposes are defined:

- Home-based work
- Home-based elementary or middle school
- Home-based high school
- Home-based college/university
- Home-based shopping
- Home-based other
- Non-home-based from work
- Non-home-based from other (note work)

5.2.4 Cross-Classification Approach

The procedure used for the PACOG trip production model is a cross-classification technique. Cross-classification offers the advantage that trip rates can be applied as a series of non-linear relationships. It has been shown that the number of trips generated by a household does not behave in a purely linear manner. For example, a three-person household does not make three times as many shopping trips as a one-person household. The second advantage that cross-classification provides is that it reduces the error associated with using zonal averages for household income and size. Cross-classification analysis is based on this fundamental assumption that trip generation rates are neither continuous nor linear in nature, and that the defined categories of independent variables are stable across the sample and through time.

For the PACOG study area, trip rates are estimated at the most disaggregate level available – the household – and continue to use the Pueblo Front Range 2010 Household Travel Survey¹². The survey effort began in August 2009 and concluded in the fall of 2010. The survey looked at urban household travel behavior along Colorado's Front Range – from Fort Collins to Pueblo. Before this effort, surveys were done separately in each individual geographic area. A total of 989 households in Pueblo County participated in the survey effort. **Figure 11** shows the location of the sample households in the PACOG region.

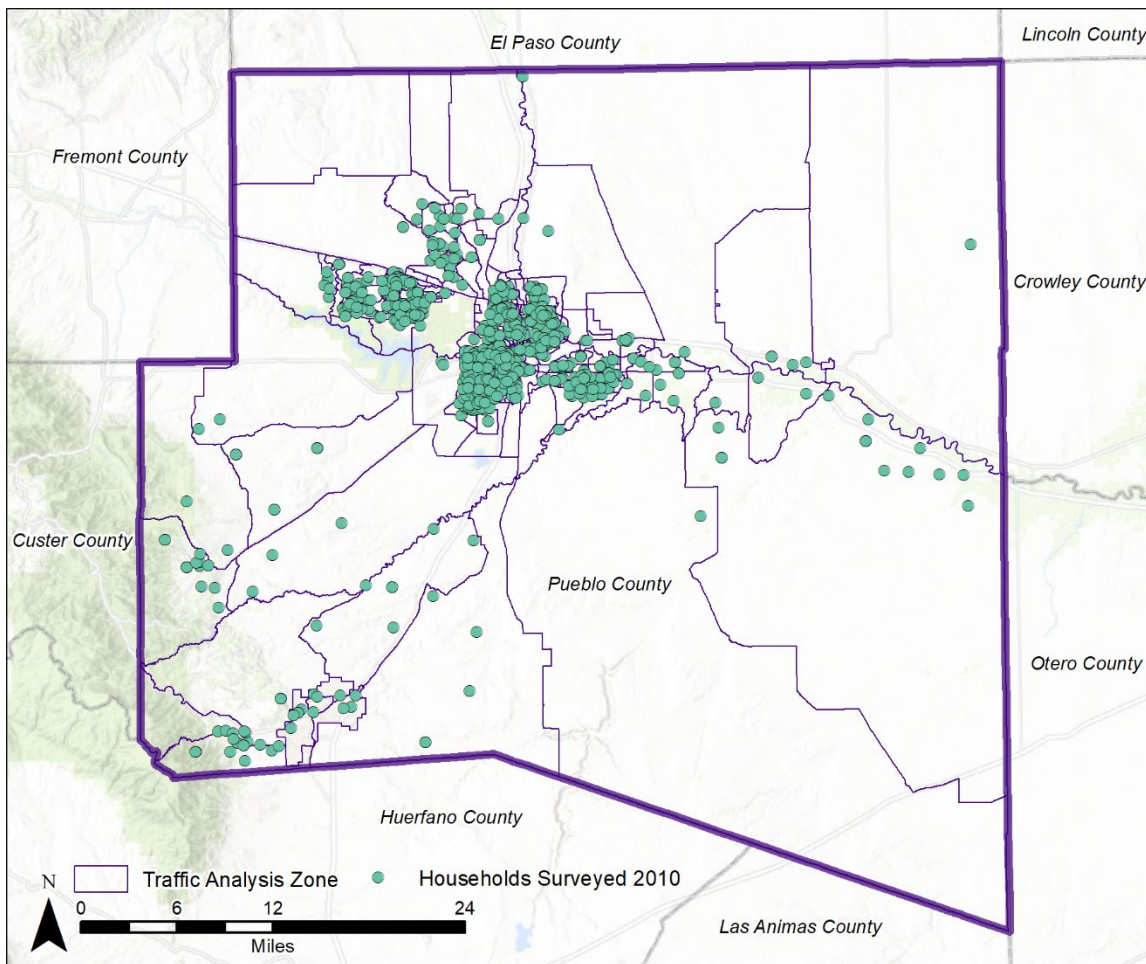

Figure 11: Front Range 2010 Surveyed Households

¹² Front Range Travel Counts: PACOG Household Travel Survey Final Report, NuStats, July 2012.

The survey database was used in the development of household trip rates by purpose for the trip generation step. It was also used to revise the trip distribution, mode choice, trip length, auto occupancy and time of day information. The survey responses contain records representing households, persons, and trips in Pueblo County¹³

Each trip record of the home interview was tagged with the appropriate income and household size indicator. The number of regional trips was then summed for each trip purpose, by both income and size category. The mean household trip production rate was calculated by dividing the number of trips by the number of households for each income and household size category. The results are the trip rates shown below in **Table 24** through **Table 31**. The trip production rates were then applied to the households by income and household size category for each TAZ. The result was trip productions for each TAZ for each trip purpose.

Table 24: Home-Based Work Trip Production Rates

Income	Household Size				
	1	2	3	4	5+
less than \$41,999	0.38	1.02	1.09	1.16	1.16
\$41,999 to \$49,999	0.73	1.27	1.44	1.82	1.82
\$50,000 to \$65,999	0.70	1.70	1.56	2.61	2.61
over \$65,999	0.70	1.79	2.37	2.35	2.35

Table 25: Home-Based Other Trip Production Rates

Income	Household Size				
	1	2	3	4	5+
less than \$41,999	0.56	1.15	2.46	2.73	3.58
\$41,999 to \$49,999	0.54	1.47	2.46	4.43	6.52
\$50,000 to \$65,999	0.68	1.30	2.41	3.26	4.38
over \$65,999	0.60	1.38	1.79	4.06	5.25

Table 26: Home-Based Shop Trip Production Rates

Income	Household Size				
	1	2	3	4	5+
less than \$41,999	0.64	1.00	1.69	1.36	1.81
\$41,999 to \$49,999	1.00	1.73	1.74	2.17	2.79
\$50,000 to \$65,999	1.04	1.71	2.41	2.10	2.10
over \$65,999	1.20	2.12	1.65	1.56	1.60

Table 27: Non-Home-Based Work-Related Trip Rates

Income	Household Size				
	1	2	3	4	5+
less than \$41,999	0.20	0.60	0.71	0.82	0.82
\$41,999 to \$49,999	0.72	0.54	1.18	1.74	1.74
\$50,000 to \$65,999	0.70	0.84	0.98	1.23	1.23
over \$65,999	0.85	1.57	1.87	1.84	1.84

¹³ Regional Travel Survey Summary Report, Pueblo, CO, NuStats, 2011.

Table 28: Non-Home Based Other Related Trip Rates

Income	Household Size				
	1	2	3	4	5+
less than \$41,999	0.84	1.29	1.46	3.55	3.55
\$41,999 to \$49,999	0.79	1.63	2.05	3.70	4.92
\$50,000 to \$65,999	1.08	1.57	2.34	3.00	4.00
over \$65,999	1.05	1.47	2.19	3.68	3.72

Table 29: Home-Based Elementary/Middle School Trip Production Rates

Income	Household Size			
	2	3	4	5+
less than \$41,999	0.13	0.23	0.36	0.70
\$41,999 to \$49,999	0.02	0.28	0.70	0.98
\$50,000 to \$65,999	0.01	0.12	0.97	0.89
over \$65,999	0.01	0.31	1.44	1.30

Table 30: Home-Based High School Trip Production Rates

Income	Household Size			
	2	3	4	5+
less than \$41,999	0.04	0.08	0.11	0.14
\$41,999 to \$49,999	0.04	0.18	0.17	0.17
\$50,000 to \$65,999	0.01	0.10	0.39	0.50
over \$65,999		0.29	0.30	0.39

Table 31: Home-Based College/University Trip Production Rates

Income	Household Size			
	2	3	4	5+
less than \$41,999	0.07	0.08	0.09	0.10
\$41,999 to \$49,999	0.02	0.15	0.22	0.22
\$50,000 to \$65,999	0.01	0.32	0.29	0.29
over \$65,999	0.01	0.15	0.13	0.11

5.3 Trip Attraction Models

Trip attraction models are the complement of trip productions. They are calibrated from household travel survey data using a process referred to as “aggregate cross-classification.” This process can be used because the “type of ending place” that a person traveled to is generally known from the household survey efforts. The type of ending place can be used to determine the land use at the attraction end: residential, basic, retail, or service. The resulting number of trips attracted to each land use can be divided by the appropriate independent variable to estimate the trip attraction rates. These are presented in **Table 32**. The socioeconomic (independent) variables used by the PACOG travel model are households, school enrollment at three levels, basic employment, retail employment, government employment, and service employment. These variables were summarized for the study area. Employment data and school enrollment were also collected and verified.

Regional totals for trip productions and attractions calculated using survey-based, cross-classified trip rates, may be similar, but not exactly equal. In the distribution step of the model, zonal attractions are used to distribute trip productions (origin of non-home-based trips or non-home end of or non-home end of (trips to and from work) to employment location zones. Households are the most verifiable zonal attribute. Thus, after the attraction equations are applied, the home-based trip attractions are balanced to match total home-based trip productions.

5.3.1 Home-Based Work (HBW)

The home-based work (HBW) attraction models are stratified by household income group. This approach ensured consistency with the trip production approach by linking productions by income group with trip attractions by income group. A recent report including a survey of sixteen MPOs¹⁴ provided guidance is checking the attraction rate values.

5.3.2 Home-Based School (School)

The home-based school trip attractions are provided for each school level - elementary/middle, high school, and college. These trips are best predicted using school enrollment alone and are balanced to the productions. Because the 2010 Pueblo Front Range Survey did not explicitly break out school trips by the age of the traveler, a step to link the trip with the person traveling was added to the survey processing.

5.3.3 Home-Based Shop (HBShop)

The home-based shop trip attraction rate is generally tied to retail employment. Given the growth in service jobs, and the blending of retail and service activity, for example, in a copy shop, tax accountancy or health club, service employment was added to this trip purpose attraction equation.

¹⁴ National Cooperative Highway Research Program (NCHRP), Travel Demand Forecasting Parameters and Techniques. Report 716, National Academy Press, 2012.

Table 32: Trip Attraction Rates

Trip Attraction Purpose	Households	Retail Employees	Service Employees	Basic Employees	Government	Elementary School Enrollment	High School Enrollment	College Enrollment
Home-Based Work								
Income 1	0.006	0.367	0.500	0.230	0.270			
Income 2	0.006	0.719	0.631	0.320	0.631			
Income 3	0.006	0.509	0.361	0.460	0.631			
Income 4	0.020	0.284	0.239	0.360	0.590			
Home-Based School								
HB Elementary School						1.100		
HB High School							0.800	
HB College								1.300
HB Shop	0.0000	5.500	2.300	0.284	0.100			
HB Other	0.9000	2.100	2.100	0.208	0.184	0.100	0.100	0.100
Non-Home-Based Work	0.1240	1.877	0.100	0.793	0.200	0.100	0.100	0.100
Non-Home-Based Other	0.3270	3.735	0.198	1.533	0.200	0.100	0.100	0.100

5.3.4 Home-Based Other (HBO)

The home-based other category includes trips made for eating a meal, personal business, recreational, serving a passenger, and other unstated reasons. Because of the variety of destinations that drive this trip purpose, it is reasonable to assume that all land uses explain, in part, home-based other trip-making.

5.3.5 Non-Home-Based Work (NHBW)

Non-home-based work attractions are explained by all socioeconomic variables. The highest coefficient is associated with the retail employment variable, which suggests that a high number of trips made from work to a place other than the home are made to a retail destination.

5.3.6 Non-Home Based Other (NHBO)

The non-home-based non-work attractions are explained by all socioeconomic variables. The highest coefficient is associated with retail employment.

5.4 External Trip Model

The external trip totals guiding both internal-external and external-external trips were obtained from AADT information provided by CDOT, the City of Pueblo and Pueblo County. All internal-external attractions are assumed to occur at internal zones. Internal-external attractions were developed by assuming that attractions are equal to exogenously developed productions.

5.5 Work from Home (WFH) Adjustment to Work Trip Rates

5.5.1 Rationale for Work Trip Rate Adjustment

The Colorado Department of Public Health & Environment (CDPHE) is currently working actively to reduce air pollution from mobile sources through a variety of innovative programs. One of the strategies is to establish goals for mobile source emissions by having MPOs measure auto and truck GHG emissions in future years, test reductions strategies, and ultimately reach pre-established goals. PACOG must model GHG emissions (using the PACOG travel model and MOVES) with and without projects from planning documents (2050 RTP, TIPs) for 2030, 2040 and 2050. PACOG must achieve GHG reductions of 0.03 million Metric Tons (MMT) in 2030; 0.02 MMT in 2040; and 0.01 MMT in 2050.

PACOG requested that the 2024 update of the PACOG Travel Demand Model include a tool to measure the impact of selected GHG reduction strategies, including work from home initiatives, which would reduce some of the work trips in the region. The question that rose immediately was “How do we account for WFH trip reduction that was already in place prior to 2020?” Travel demand in the PACOG region to date has not addressed this issue, which would require the removal of a small percentage of work trips from the model. To design an accurate tool for measuring reduction strategies, a baseline needs to be established.

5.5.2 Work from Home Development and Application

Work from home (WFH) existing conditions were then accessed from ACS¹⁵ (Census) Journey to Work data for years 2019 and 2022 and reviewed. These facts emerged:

- In 2019, Pueblo County work from home WFH average was 2.8%. Across the 54 Census tracts the average value ranged from 0% to 9.7%.
- In 2022 the Pueblo County WFH average was 5.8%. Across the 57 Census tracts the average value ranged from 0% to 14.4%.
- Colorado counties vary in the average WFH percentage with 2019 averages: Denver and Douglas Counties 14%; El Paso County 8%; and Pueblo County 3%. WFH averages for 2022, collected when Covid-19 workplace changes had solidified, were Denver County 27%, Douglas County 31%; El Paso County 18%; and Pueblo County 9%. Local understanding of Pueblo with its focus on manufacturing and high-tech industrial jobs, explains why the Pueblo County WFH average tends to be lower than that of counties with a high percentage of Information Technology, sales, and related work.
- County level work from home percentages for 2020 are sufficient for the PACOG Model GHG tool; these must be stratified for the four income levels in the PACOG model.
- National research has shown that WFH share increases as the household level increases¹⁶.

Given this trend data, and the fact that WFH is continuing to evolve with employees being required in some cases to return to the office, it was asserted that the WFH percentages by income level be set at a midpoint between the 2019 and 2022 Pueblo County percentages. **Table 33** shows the final rates used to adjust work trips in the 2020 PACOG model. **Figure 12** shows the midpoint designation in plot format. The WFH values established for the 2020 base: 1%, 3%, 6% and 11% respectively, were used to reduce work trip productions permanently in the PACOG Travel Model.

Table 33: Work From Home (WFH) Percentages by Income Class Pueblo County

Year 2020 Quartiles	# of Workers	% Worked from Home	WFH Estimate for 2020 Model
INC01	18,031	0.01	180
INC02	16,133	0.03	484
INC03	10,735	0.06	644
INC04	12,953	0.11	1,425
Total	57,851		2,733

¹⁵ American Community Survey (ACS) Table C08301, years 2019 and 2022, accessed March 2024.

¹⁶ "Home-Based Workers and the COVID-19 Pandemic, American Community Survey Reports, ACS-52, April 2023, accessed March 2024.

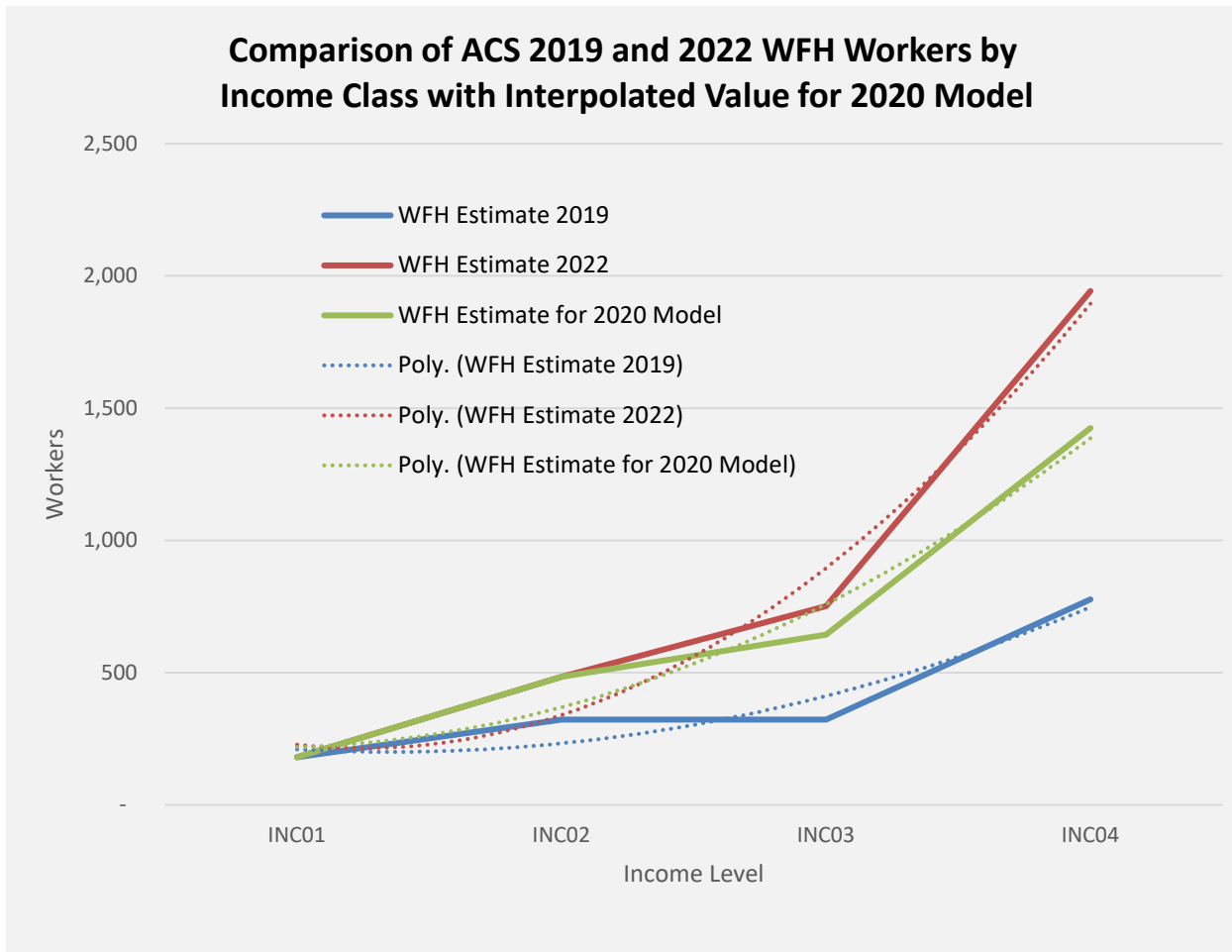

Figure 12: Midpoint Designation for Pueblo County WFH Percentages

5.6 Validation of Attraction-Production Models

5.6.1 Introduction to Trip Production

Trip production rates were developed from the most recent observed data, the 2010 Pueblo Front Range Household Travel Survey. Surveys do not provide direct estimates of zonal trip ends. Thus, there is not an observed number of trip ends to compare with model-estimated trip ends. Summary statistics such as vehicle trips per household, person trips per household, and the percentage of person trips by each trip purpose for a similar study area can be used. Guidance is available on the acceptable range of average trips per households and average trips per person.¹⁷ A very recent source of validation targets is the Transportation Research Board (TRB) online Travel Forecasting Resource¹⁸ website. This electronic site was launched in 2009 to serve as “a national travel forecasting handbook to be developed and kept current providing salient information to those practicing travel demand forecasting”. The Travel Forecasting Resource was a valuable resource to the PACOG model validation. Finally, the 2024 report on Household Travel characteristics from the 2009 National Household Travel Survey was used¹⁹.

Some key issues are related to the review of average trip generation production rates:

- Activity-based travel models are becoming “standard practice” in many larger urban areas. The need for well-built four-step models, however, is still strong. Continuing research and tabulation are available and needed for four-step model work.
- City or MPO size is not automatically thought to be a direct factor in the average number of trips per household. Smaller cities or towns have been shown to have trip-making rates as high as, or higher than, those in large cities. There is also anecdotal information regarding a decrease in motorized trip rates in U.S. cities between 2000 and 2024. More study of this possible trend is needed in Pueblo, and indeed across the U.S.
- Household travel survey fidelity to actual household trip patterns may be a better indicator of trip rate than is city size. The continued realization that surveyed trip rates do not capture the full extent of household travel, and that non-work trips are the most likely to be under-reported continues to affect travel model trip production rate study.
- With the increase in total trips made by U.S. households comes a decrease in the percentage of work trips of total trips. Some of this shift is due to better reporting on household travel surveys.
- Some recent work during survey data collection in the U.S. used a joint diary and GPS (Global Positioning Satellite) tabulation to capture the movement of a household’s vehicles. This strategy records all motorized trips, not just those reported in the diary part of the survey. For example, in a 2013 survey effort in Albuquerque, New Mexico, an overall rate of underreporting of approximately 18% of trips occurred. These trips were detected by GPS but not reported by participants. To further leverage the data collected by the GPS subsample in this survey effort, a statistical model was tested using the trips database and key socio-demographic variables to generate Trip Rate Correction Factors. The results indicated that household vehicle ownership, trip duration, and household size were significantly associated with trip under-reporting. The analysis suggested that likely mis-reporters were respondents between 40-49 years of age, respondents who were either not employed or were students, and households with 0-1 vehicles. Trip duration was also a significant variable in reporting accuracy. In this study, trips greater than 7 minutes in length were more likely to be reported than trips less than 7 minutes in duration.
- There is some evidence that trip rates have a ceiling—households reach a saturation point at which additional trips are neither necessary nor pleasant. In the current decade, U.S. cities may be at this point. Generational differences may also be at play.

¹⁷ Transit Cooperative Research Program “Characteristics of Urban Demand Report 73”, National Academy Press, 2002.

¹⁸ Transportation Research Board (TRB) online Travel Forecasting Resource <http://tfresource.org/>, accessed 2014; requires registration.

¹⁹ “Summary of Travel Trends: 2009 National Household Travel Survey”, Washington, D.C. USA, US DOT, FHA, A Santos, N. McGuckin, H.Y. Nakamoto, D. Gray & S. Liss, June 2011.

5.6.2 Trip Production Validation

Validation for trip generation was prepared using the sources cited above. The first step was to review the average household and person trip making rates.

Average Household Trips - The National Household Travel Survey (NHTS)²⁰ is a good source of both the trend and the current average of trips per household and trips per person. The average weekday household trip rate is calculated by dividing the total number of trips produced in trip generation by the total number of households in 2020. Trips per household are shown from 1983 to 2022 in **Table 34**. Trips per household increased between 1983 and 2001 then declined between 2001 and 2022. The person trips per household of 9.65 weekday trips for all purposes estimated for Pueblo is generally consistent with these national rates.

Table 34: Trends in Average Daily Household Trips (NHTS)

Year	1983	1990	1995	2001	2009	2017	2022
Daily Household Trip Rate	7.92	9.45	10.76	10.90	9.30	8.18	5.18

Average Person Trips - The average weekday person trip rate is calculated by dividing the total number of trips produced in trip generation by the total number of persons living in households in 2020. This trend is shown in **Table 35** a summary of travel characteristics from the NHTS. As in the household trip rate, travel increased up to year 2001 then declined between 2001 and 2022. The person rate of 3.78 weekday trips per person for all purposes estimated for Pueblo is generally consistent with these national rates.

Table 35: Trends in Average Daily Household Trips (NHTS)

Year	1990	1995	2001	2009	2017	2022
Daily Person Trip Rate	3.76	4.30	4.09	3.79	3.37	2.28

A review of daily per capita trip rates from Albuquerque, NM; Tucson, AZ; Fort Collins, CO; Madison, WI; and Sacramento, CA was conducted. These cities have similarities to Pueblo both in size, region (Western states), and/or local characteristics, and as such, can provide reference points with respect to the daily trip rates estimated from their household travel surveys. A summary is provided below.

Daily Per Capita Trip Rate

U.S. cities surveyed daily person trip rate range is 2.40–5.55. Cities similar to Pueblo include:

Albuquerque, NM:	Rate 3.97
Madison, WI:	Rate 3.83
Tucson, AZ:	Rate 3.54

Pueblo rate of 3.78 is within these limits.

Daily Household Trip Rate

For the U.S. cities surveyed the daily household rate range is 7.02–12.99. Cities similar to Pueblo include:

Albuquerque, NM:	Rate 10.08
Fort Collins, CO:	Rate 10.66
Sacramento, CA:	Rate 9.72

Based on this data, the Pueblo rate of 9.65 is within these limits.

²⁰ 2022 National Household Travel Survey, Summary of National Trends, Report no. FHWA-HPL-24-009, published 2024.

Percentage of Home-Based Work Trips of Total

U.S. cities surveyed have a range of 13 percent to 28 percent home-based work trips as a percentage of total daily trips. Cities similar to Pueblo include:

Albuquerque, NM:	HBW 17.7 percent
Fort Collins, CO:	HBW 13.0 percent
Tucson, AZ:	HBW 17.6 percent

Percentage of Trips by Purpose – There is value in looking at the percentage of trips produced by each of the three major trip types: home-based work (HBW), home-based other (HBO), and non-home-based (NHB). Evidence points to a trend of HBW trips taking up a diminishing percentage of total daily trips in recent years. Surveys from the 1970s and early 1980s show HBW at 19 percent to 28 percent trending in the mid 25 percent area. More recent surveys set the HBW percentage of total range at 13 percent to 28 percent trending in the low 20 percent. Based on this data, the Pueblo home-based work trip percentage of 13 percent of total daily trips is within normal limits.

5.6.3 Trip Production Ratio Validation

On the production side, it is recommended that selected trip production totals be compared to observed “on-the-ground” socioeconomic totals. Two measures are suggested: (1) Home-based work production ratio to total employment; (2) and Home-based shop productions to retail employment. In the Pueblo area, the home-based work person trip production ratio to total employment is 1.14. The retail productions per retail worker are 13.38.

5.6.4 Total Productions versus Total Attractions

Table 36 shows the unbalanced productions and attractions for each of the eight trip purposes. The total number of attractions (about 616,695) is about 3 percent lower than the total number of productions. The home to/from work difference is likely due to a more accurate capture of employment locations for the updated 2020 base year.

Table 36: 2020 Total Productions and Attractions by Trip Purpose

Trip Purpose	Productions	Attractions	Difference	% Difference
Home Based Work	85,227	85,260	33	0%
Home Based Elementary School	23,304	21,439	-1,864	-8%
Home Based High School	10,605	9,913	-693	-7%
Home Based College	10,597	9,750	-848	-8%
Home Based Shop	119,405	109,852	-9,552	-8%
Home Based Other	159,628	148,490	-11,138	-7%
Non-Home-Based Work	78,202	82,682	4,480	6%
Non-Home-Based Other	149,196	149,309	113	0%
All Trip Purposes	636,164	616,695	-19,469	-3%

Overall, the trip generation model performs within the limits indicated by national practice while reflecting in a reasonable manner the local Pueblo observed information on households, schools, and employment.

5.7 Summary

There were no major changes to the trip generation model in the updated 2020 model. The most recent household survey data continued to serve as the observed data for trip rates. Socioeconomic updates, however, captured the most recent input data to the models. The PACOG model:

- Continued to use the trip rates and trip distribution targets developed from the 989 households in the 2010 Pueblo Front Range household travel survey.
- Reviewed and verified the trip attraction rates established in the previous PACOG model.
- Reviewed the results of trip generation to ensure results consistent with recent national averages.
- Referenced Covid-19 impacts of trip rates and selected a “middle ground” that reflects HBW activity on the ground in the PACOG region.

6 Special Generators

6.1 Introduction

The special generator approach is important to capture activity at sites that are not accounted for by the household trip generation process. Trip generation rates for most sites were obtained from NCHRP 365 (update of NCHRP 187)²¹. The sites and vehicle trip generation rates included are shown in **Table 37**.

The areas of the special generators were estimated from computerized zone and geographic maps. Vehicle trips were converted to person trips (where appropriate) assuming an auto mode share of 1.0 and average auto occupancy of 1.3 persons per vehicle (which is the average for Pueblo for the trip types included). The table shows the special generator name and the vehicle trips per acre that are used for 2020. The special generator attractions are added to the standard trip generation attractions during the model run. For example, if the trip generation module produced 500 trip attractions for a zone and the special generator produced 300 attractions, the file would simply be modified to show 800 trip attractions for that zone. Note that the special generator trips will not change over time unless one of the sites is expanded or reduced in size.

Table 37: Special Generators & Rates

TAZ	Name	Trip Rate
23	Mineral Palace Park	60 vehicles / acre
54	City Park	60 vehicles / acre
59	Pueblo Country Club	7 vehicles / acre
83	Elmwood Golf Course	7 vehicles / acre
92	YMCA (Future)	1.64 vehicles / 1000 SF GFA
106	Walking Stick Golf Course	7 vehicles / acre
121	Lake Minnequa	3.6 vehicles / acre
146	Desert Hawk Golf Course	7 vehicles / acre
196	Hollydot Golf Course	7 vehicles / acre
155	Juniper Breaks Rock Canyon	Pueblo Lake State Park entrance: trip generation per state visitor counts and forecasts
167	Northern Plains North Shore	Pueblo Lake State Park entrance: trip generation per state visitor counts and forecasts
203	Arkansas Point South Shore	Pueblo Lake State Park entrance: trip generation per state visitor counts and forecasts

6.2 Pueblo Airport (PUB)

Air passenger trips constitute a distinct travel segment in a regional travel demand model. For the PACOG region, there is one commercial airport that requires review, the Pueblo Memorial Airport (PUB) located at 31201 Bryan Circle, Pueblo, CO 81001. The TAZ ID of the airport zone is 28 as shown in **Figure 13**.

Pueblo falls under the [Essential Air Service](#) program in which the U. S. Government subsidizes an airline to provide air service to a city. This federal program guarantees smaller communities access to the national transportation grid by subsidizing carriers that fly from the smaller communities to hub airports. This subsidy comes up for bid every two years; therefore, Pueblo has seen its air service provider frequently change. There have also been times where there has been no commercial air service to Pueblo, such as in the spring of 2014 and the summer and fall of 2015.

²¹ National Cooperative Highway Research Program, Travel Estimation Techniques for Urban Planning, Report 365," National Academy Press, 1998.

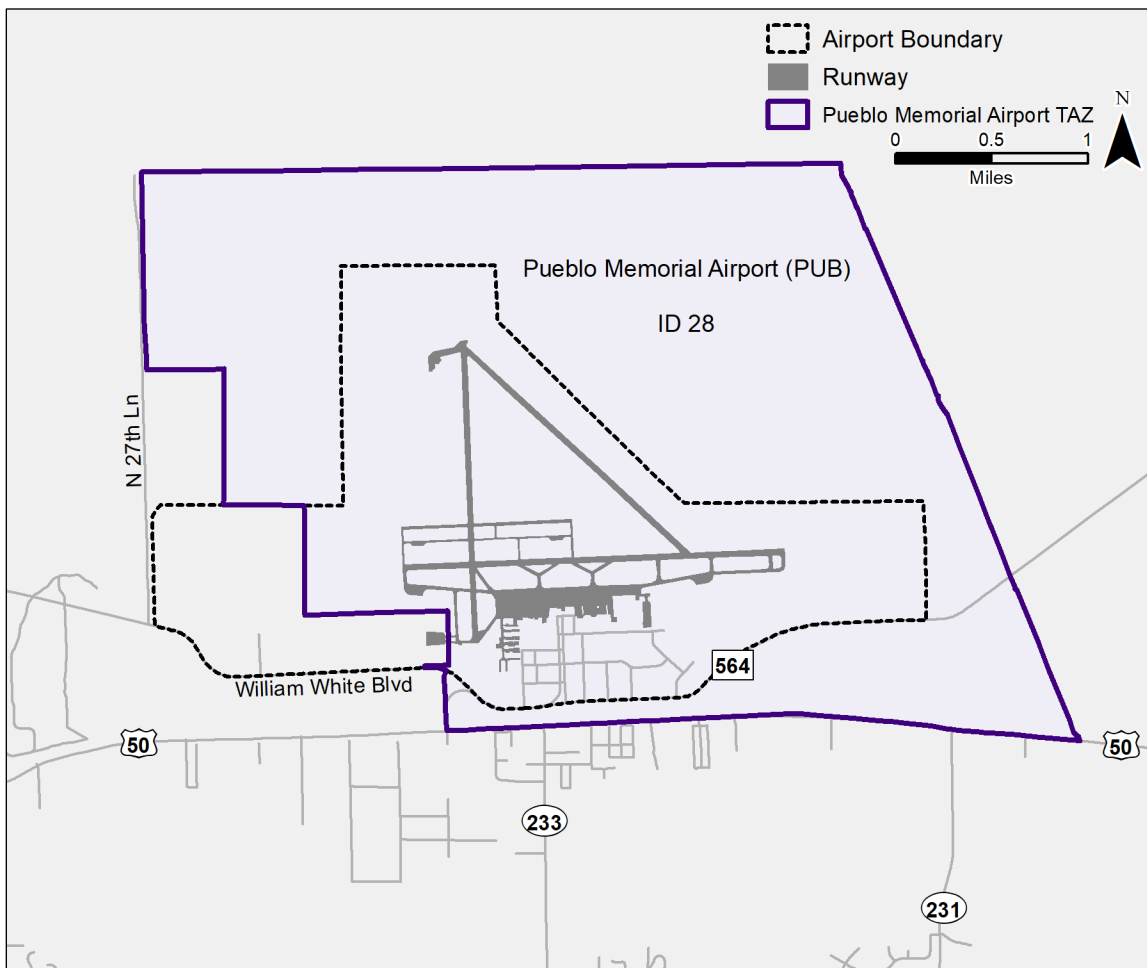

Figure 13: Pueblo Airport Area

Up until the mid-1990s, Pueblo was served by multiple airlines and for much of the year 1991, four airlines were operating at Pueblo simultaneously: America West, TWA, Continental Express, and United Express. Pueblo has also seen mainline jet service (727s, 737s, and MD-80s) by four airlines. Since 1995, however, service has only been provided by one airline with commuter or regional jet flights to Denver apart from the Allegiant Air service in 2010–2012.

Starting January 2023, Southern Airways Express LLC has been offering daily scheduled air service between Pueblo and Denver, providing an air commute link between Pueblo and Denver International Airport. Under the contract, Southern Airways will provide Pueblo with a total of 24 weekly nonstop round trips to Denver using a 9-seat Beechcraft King Air 200 plane. In exchange for the airline’s willingness to serve the market, the federal government will pay an annual subsidy of \$2.9 million in 2023 and \$3.06 million in 2024, according to the department’s order²².

The travel model currently does not reflect these boardings and alighting air passengers generated by the Southern Airways Express service. The airport TAZ, however, contains significant employment, related to general aviation workers as well as to other employment types, which is included in the PACOG model.

²² *The Pueblo Chieftain*, “We Have Liftoff: Southern Airways begins flights from Pueblo to Denver,” <https://www.chieftain.com/story/business/2023/01/18/southern-airways-offering-24-weekly-flights-between-pueblo-and-denver/69816584007/>, January 18, 2023.

7 Distribution Model

7.1 PACOG Distribution Model Formulation

Within the PACOG travel model, trips are distributed geographically, for all but the external-external trip purpose, using a gravity model-based procedure. This approach was also used in the previous PACOG travel models. The basic theory underlying the gravity model is that the number of trips between two zones is directly proportional to the number of trips produced at the production zone and the number of trips attracted to the attraction zone and inversely proportional to the impedance between the two zones.

$$T_{i,j} = P_i \times \left(\frac{A_j F_{i,j}}{\sum_{k=1}^n A_k F_{i,k}} \right)$$

where: $T_{i,j}$ = trips from zone i to zone j

P_i = trip productions in zone i

A_j = trip attractions in zone j

$F_{i,j}$ = the “attractiveness” between zone i and zone j

The “attractiveness” factor in the equation ($F_{i,j}$), often referred to as the “friction factor,” represents the spatial separation such that as separation between zones increases, the attractiveness to travel between these zones decreases. The gravity models used in the PACOG travel model distribution procedures were calibrated by trip purpose to observed data (the 2010 Front Range Pueblo household travel survey data). As in previous PACOG travel models, the formulation (gamma or exponential) used for the PACOG gravity model “friction factor” varied by trip purpose. The gamma function was used for all person trips and the exponential function for all truck trips. The formulations of these functions are as follows:

1) the gamma function:

$$F_{i,j} = a \times t_{i,j}^b \times e^{-c \times t_{i,j}}$$

2) the exponential function:

$$F_{i,j} = a \times e^{-c \times t_{i,j}}$$

where: $t_{i,j}$ = the travel impedance between zone i and zone j

a, b, and c are calibrated coefficients.

e = the base of the natural logarithm (2.71828)

Each of the “friction factor” (F_{ij}) formulations (gamma or exponential) used by the PACOG travel model for gravity model-based trip distribution include a travel impedance term, $t_{i,j}$. Although composite impedances including costs for travel (fuel, depreciation, tolls, fares, etc.) are often used for representing $t_{i,j}$, the PACOG gravity model formulations use travel times alone for the interzonal travel impedance ($t_{i,j}$) friction factor terms. The PACOG model incorporates a feedback loop from assignment to distribution to utilize the most recent congested times in distribution.

Testing was considered to determine the value of adding “terminal times” at the origin and destination of each time skim. Standard practice no longer supports this step which is seen as a constant on the zone-to-zone times with little explanatory value and therefore this step was not implemented with this current update.

Recognizing that intrazonal travel times may be needed for model application, these times were also calculated and added to the initial congested auto travel time skims. The intrazonal travel times were

calculated using a standard process whereby the zone-to-zone travel time was assumed to be one half of the average of travel time between that zone and all adjacent zones. The calculation assumes that roughly one half of the intrazonal travel time relates to the origin zone, with the other half of the travel time to the destination zone. Averaging this function for all adjacent zones has the effect of dampening the effect on the calculation of anomalies that may be created by irregular zone shapes or uneven major network coverage. TransCAD standard procedures were available to process the required calculations.

7.2 Distribution Model Development

7.2.2 Gravity Model Calibration

The gravity model was first calibrated in 1993 using the 1990 Household Survey data for Pueblo County. The 1993 trip distribution coefficients served as the starting point for the 2010 model update. The distribution was calibrated using the survey, testing the fit of the resulting gamma function gravity model formulations, revising coefficients, and optimizing the model's performance. Trip length frequency distributions (TLFDs) were prepared for each purpose using utility programs in TransCAD GISDK. Iterative testing was done with the model coefficients until a fit with observed distributions was achieved. For the current 2020 update, observed data remains the 2010 Front Range Household Survey.

Figure 14 through **Figure 19** show the fit of modeled travel time distribution vs. observed travel time distribution for each trip purpose. Final coefficients are presented in **Table 38** together with a comparison of "observed" and modeled average trip lengths.

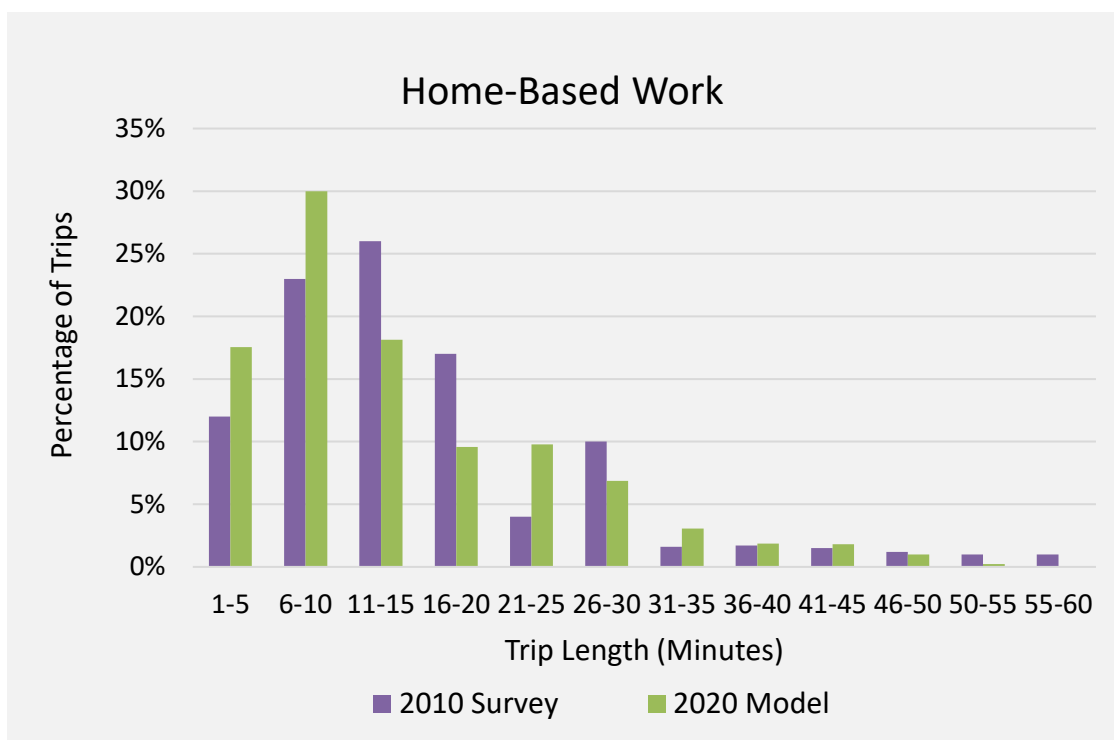

Figure 14: Home-Based Work Trip Length Frequency Comparison

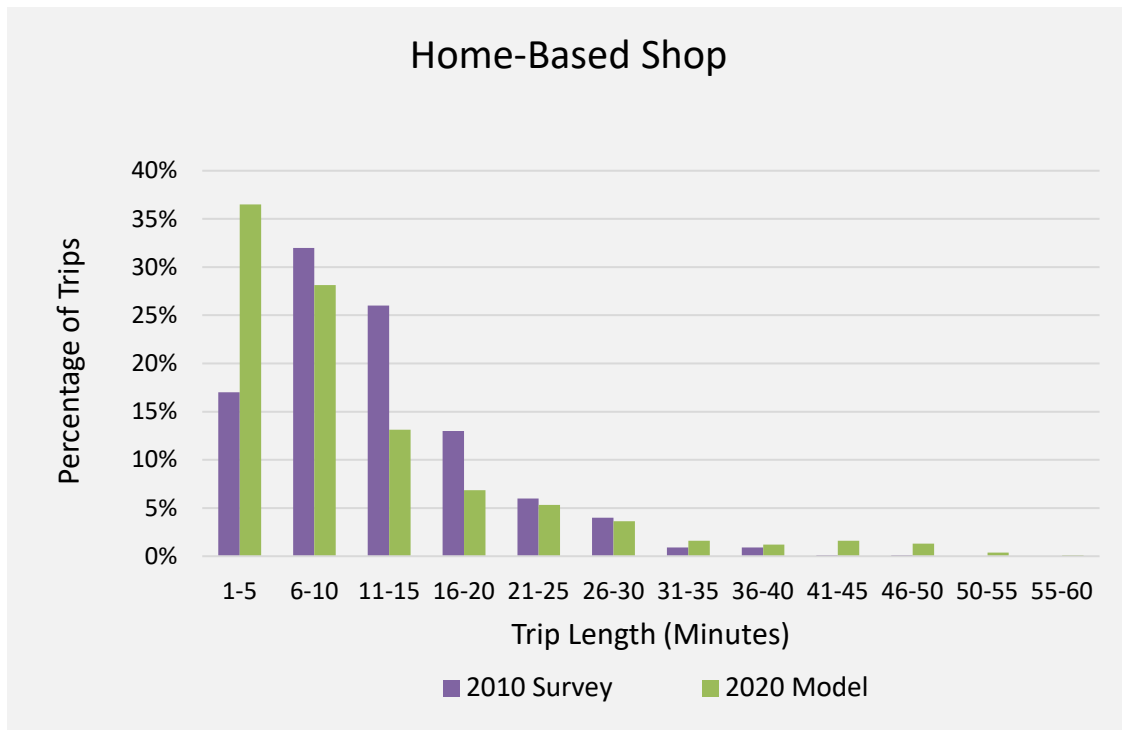

Figure 15: Home-Based Shopping Trip Length Frequency Comparison

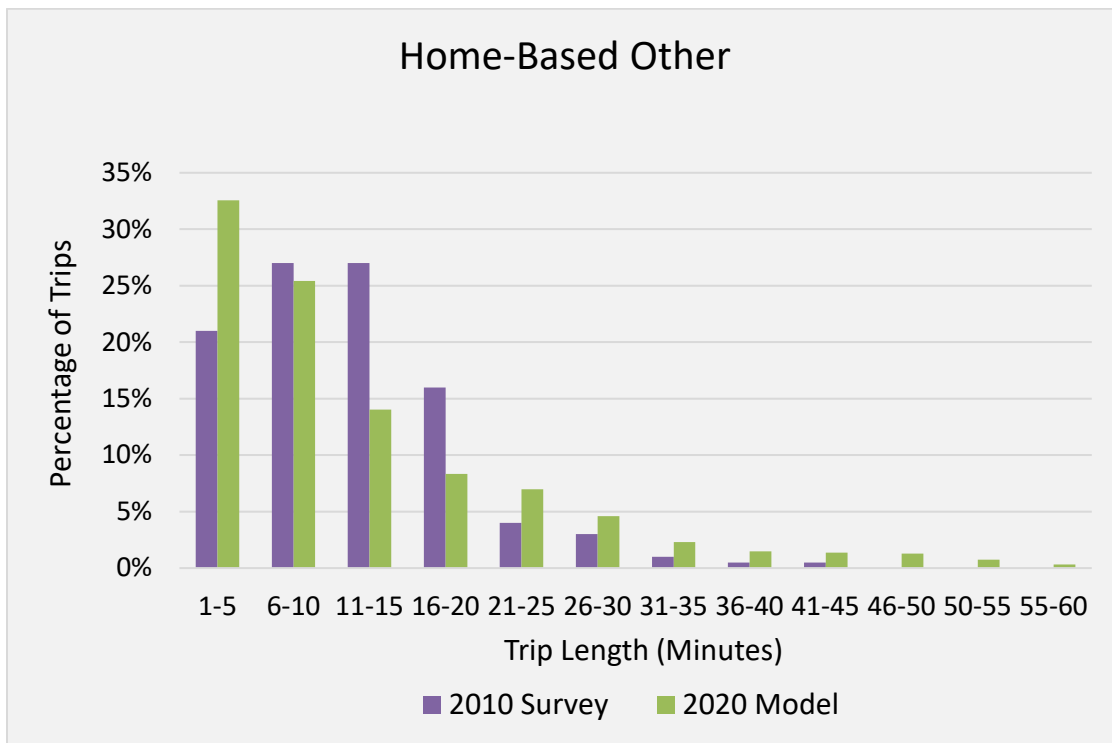

Figure 16: Home-Based Other Trip Length Frequency Comparison

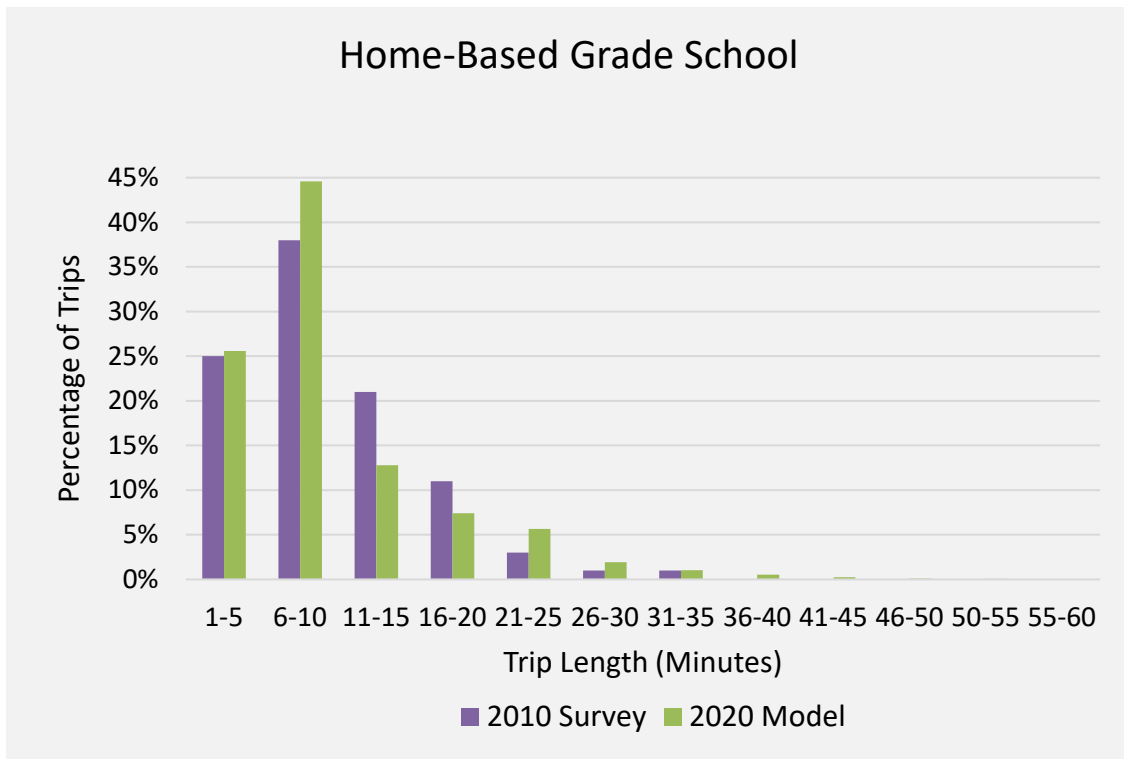

Figure 17: Home-Based Elementary & Middle School Trip Length Frequency Comparison

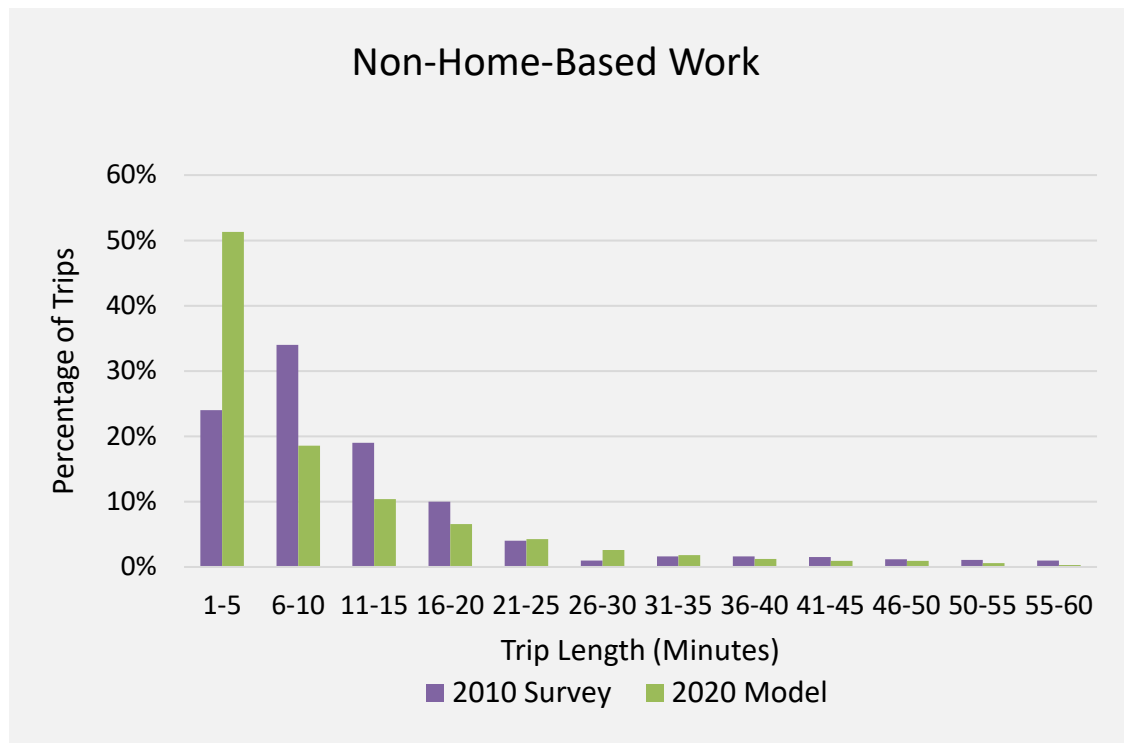

Figure 18: Non-Home-Based Work Trip Length Frequency Comparison

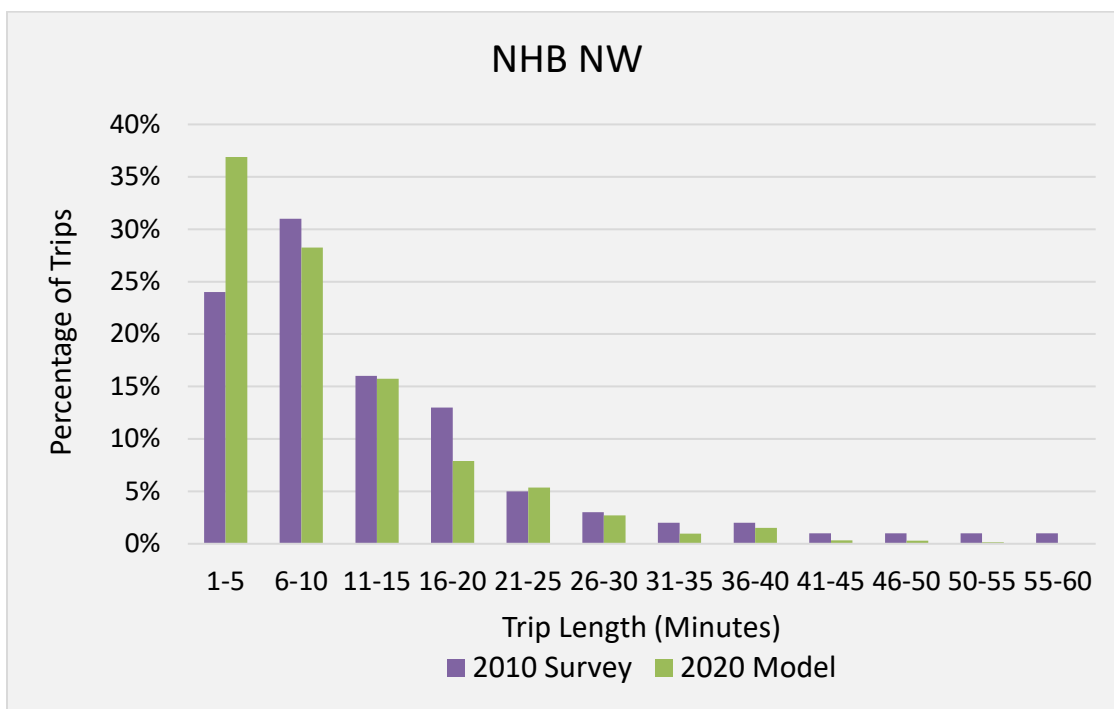

Figure 19: Non-Home-Based Other Trip Length Frequency Comparison

Table 38: Trip Distribution Parameters by Purpose

Trip Purpose	Friction Factor Function Coefficients				Average Trip Length	
	a	b	c	Function	2010 Front Range Pueblo Survey	2020 Modeled
Home-Based Work						
Low-Income	28507	0.3260	0	gamma	15.8	10.3
Lower Middle Income	28507	0.3568	0	gamma	15.8	10.7
Middle Income	28507	0.0200	0.123	gamma	16.7	13.1
Upper Income	28507	0.0200	0.2	gamma	17.5	20.0
Home-Based School						
Home-Based Elementary	139173	0.1000	0.2000	gamma	10.8	10.5
Home-Based High School	43057	1.0000	0.0500	gamma	12.1	12.1
Home-Based College	28507	0.0200	0.1230	gamma	20.5	12.6
Home-Based Shop	139173	1.2534	0.0345	gamma	13.5	11.8
Home-Based Other	139173	1.2850	-0.0200	gamma	13.0	13.3
Non-Home-Based Work	219113	1.3320	0.0100	gamma	12.4	13.9
Non-Home-Based Other	219113	1.0561	0.0591	gamma	10.9	10.8

7.2.3 External-External Trip Distribution

External-external (E-E) trip distribution was performed using the Fratar process. This approach is used since the true origins and destinations of the trips are not known. For example, a trip traveling through Pueblo County on I-25 could have started in Denver and be destined for Albuquerque or to many other points south.

Typically, external-external trip tables are estimated using a base year trip table obtained from an external station survey. Since no such survey was available for Pueblo in 2024, a different technique had to be used. This approach is adapted from the National Cooperative Highway Research Program (NCHRP) guidance on travel model development.²³

Specifically, the starting point was the AADT at each of the eight external portals. A set of factors was established to calculate both the percent through traffic at each external station and the distribution of the through traffic to the other external stations. As an example, some of the traffic observed at the I-25 portal on the north continues through the county to exit at I-25 south. The scores were based on the functional classification of the external station as well as the volume and type of traffic at each candidate destination external portal. Certain movements were disallowed – if, for example, the trip is a U-turn or another illogical movement. The starting external movements are shown in **Table 39**. The estimated through traffic can then be calculated to match external-external origins and destinations at each external station using derived growth factors and Fratar Model methods. The rows and columns are balanced to achieve symmetry about the diagonal. Through trips were estimated for autos and two classes of trucks separately.

Table 39: External Station 2020 Traffic Worksheet

Location	TAZ ID	2-Way AADT	2 Way SUTs	2 Way MUTs	IX Productions	XX AADT Trips	XX Origins	XX Destinations
I-25 (North)	401	29,000	941	2,570	19,500	9,500	4,750	4,750
SH 96 E	402	1,000	42	40	700	300	150	150
US 50 E	403	3,700	141	370	2,800	900	450	450
I-25 South	404	8,100	357	1,160	600	7,500	3,750	3,750
SH 165 W	405	800	28	30	600	200	100	100
SH 78 W	406	1,000	37	30	800	200	100	100
SH 96 W	407	1,000	28	60	800	200	100	100
US 50 W	408	8,100	157	370	6,300	1,800	900	900
Total		52,700	1,731	4,630	32,100	20,600	10,300	10,300

The future year external movements for truck and auto were estimated using the growth factors provided by CDOT, and the Fratar Expansion calculation process.

²³ National Cooperative Highway Research Program (NCHRP) Travel Estimation Techniques for Urban Planning (Report 365), TRB National Academy Press, 1998.

8 PACOG Transit Modeling

With this PACOG Travel Demand Model update, transit routes, stops, and service characteristics are included in the PACOG model for the first time. Additional transit network information is used to support transit skimming which is an input to mode choice modeling and later in transit assignments. Roadway network detail and data attributes were expanded to support transit modeling as well.

8.1 Pueblo Transit System

The Pueblo Transit System consists of eleven bus lines in 2023 offering peak and off-peak service with differing frequencies. All buses begin and end at the Pueblo Transit Center in downtown Pueblo. There were approximately 1,600 weekday boardings in 2022, down from about 3,000 in 2016. This bus system served as the input for the transit model. **Table 40** and **Figure 20** show the system profile.

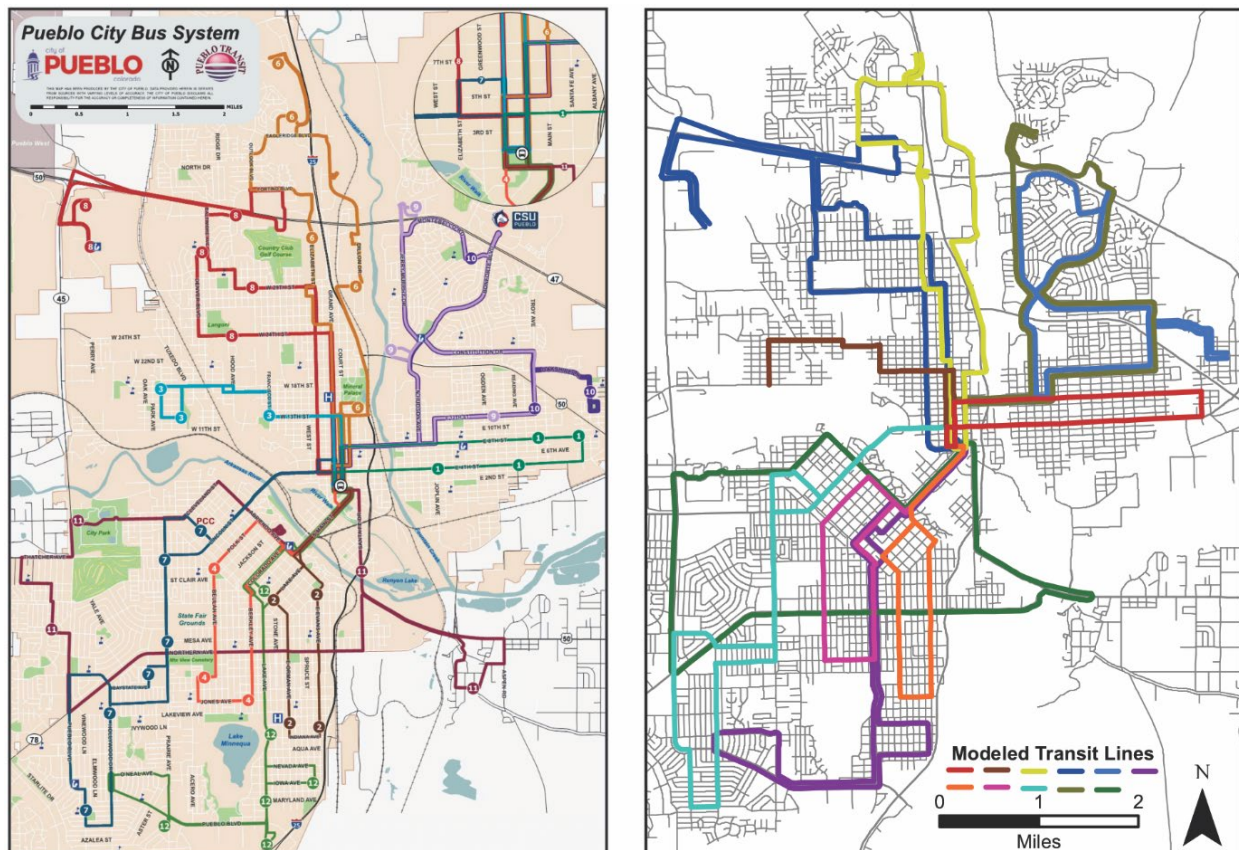

Figure 20: Pueblo Transit System, Observed and Modeled

Table 40: Pueblo Transit System

Bus Line	Headways		Line Haul Time in Minutes
	Peak	Off Peak	
1-Eastside	30	60	25
2-Bessemer	30	60	25
3-Irving Place	30	60	25
4-Berkley/Beulah	30	60	25
6-Pueblo Mall	60	30	50
7-Highland Park	30	30	55
8-Hwy 50-West	60	60	50
9-University	60	60	55
10-Belmont	60	60	50
11-Red Creek Ride	60	60	55
12-Lake Avenue	30	60	55

8.2 Pueblo Transit Model Processing for Mode Split

During a model run, the model script calls a macro that conducts transit skimming. The process begins by generating a transit network that is sensitive to:

- **Peak Headway** – “PK_Headway,” is an attribute of the Transit Route System that represents the time between buses along a given route during peak service periods.
- **Walk Time** – “WalkT” is an attribute of the roadway file and is used to estimate the travel time due to the walk components of a transit trip (walk to bus stop from trip origin, walk to transfer, walk to destination).
- **In Vehicle Travel Time** – IVTT is an attribute of the roadway file and is used to estimate the travel time due to the in-vehicle portion of a transit trip (riding on the bus, waiting for other riders to get on/off the bus). The IVTT value is computed inside the SPCAP portion of the script, and the default value uses 2 x Auto Travel Time to account for the frequent stops and slower overall travel speeds of buses in mixed traffic.

The resulting transit “network” is encoded in a TransCAD network file but is not ready to be used until Transit Settings are designated. The Transit Settings process establishes a set of weights and upper/lower limits to key variables that allow TransCAD to find the best transit path between every pair of TAZs. Some key transit path building assumptions are listed below:

- **Access/Egress Walk Time:** capped at 15 minutes, if the walk trip to/from the nearest bus stop exceeds this threshold, then transit is not feasible.
- **Initial Waiting Time:** ½ of the headway, and a maximum of 60 minutes.
- **Transfers:** maximum of 1 transfer, 40% fare on the second bus, 3-minute time penalty.

The resulting transit network and settings are then ready for skimming. The transit skimming process results in a matrix file with each of the following variables representing the characteristics of a transit trip between the zone pairs. Several key elements from the transit skim are copied into a mode choice input matrix for the mode choice step.

Transit related elements in the mode choice skims are as follows:

- **Bus Availability:** "BUS_AVAIL": computed by the skim, set to 1 if bus is feasible between zones, 0 if not feasible.
- **Bus In Vehicle Time:** "BUS_INVTT": sum of the transit journey travel time spent inside the bus between a zone pair, includes dwelling time.
- **Bus Initial Waiting Time:** "BUS_INWAIT": sum of the transit journey's time spent waiting at the initial bus stop.
- **Bus Walk Time:** "BUS_WLKTIM": sum of the transit journey's travel time spent walking to the bus stop.
- **Bus Transfer Wait:** BUS_TRWAIT: sum of the transit journey's travel time spent waiting for a transfer bus if a transfer is needed to reach the destination.

As a first effort to integrate the transit mode into the PACOG model, the above transit network and skimming approach successfully prepared a set of inputs to bring transit to the mode choice model.

9 Mode Choice

9.1 Introduction

During the mode choice step, trips from zone to zone by trip purpose are further divided into trips by various transportation modes and then converted to vehicle trips and passenger trips for the purpose of predicting vehicle flows on the roadway network and demand for alternative modes. Mode Choice models are mathematical expressions used to estimate the share of travel on each available mode given the time and cost characteristics of each mode and the demographic and socio-economic characteristics of trip makers.

The mathematical formulation of the nested multinomial logit model structure is as follows.

The generalized mode choice model structure is represented by a logit formulation. This mathematical relationship estimates the probability of choosing a specific mode using the following equation:

$$P_i = \frac{e^{U_i}}{\sum_k e^{U_i}}$$

where:

P_i	is the probability of a traveler choosing mode i ;
U_i	is a linear function of the attributes of mode i that describe its attractiveness;
$\sum_k e^{U_i}$	is the summation of the linear functions of the attributes of all the alternatives (k) for which a choice is feasible.

The utility expression for each available mode (i) is specified as a linear function which incorporates a range of variable types, including time and cost incurred by a traveler using a given mode. For example:

$$U_i = b_1 * INVTT_i + b_2 * IWAIT + b_3 * WALKT + b_4 * TRFRT + b_0$$

where:

U_i	is the utility for mode i ;
b_0	is a constant specific to mode i that captures the overall effect of any significant variables that are missing or unexplained in the expression (i.e., comfort, convenience, safety);
b_1	is a coefficient applied to a variable describing the level-of-service (in-vehicle travel time) provided by mode i ;
b_2	is a coefficient applied to a variable describing the wait time for the bus mode for the specific origin-destination pair;
b_3	is a coefficient applied to a variable describing the walk time to the boarding bus stop for the bus mode for the specific origin-destination pair;
b_4	is a coefficient applied to a variable describing the wait time if a transfer is required for the bus mode for the specific origin-destination pair.

9.2 Formulation and Nesting Structure

The travel time variables are disaggregated into in-vehicle and out-of-vehicle time for the bus mode; the out-of-vehicle time is broken out by initial wait time, access walk time, and transfer walk time. And finally, a mode specific constant reflects non-included variables such as comfort or reliability of service. The individual coefficients associated with each variable reflect the relative importance of each attribute.

In the nested logit model structure shown in **Figure 21**, the formulation employs two levels of multinomial logit models; one for the primary choice of mode among auto and transit, then a second level choice among auto driver or auto shared ride. A composite of the utilities of the auto sub-mode modes then represents each nest mode respectively in the upper tier of the model structure. This composite measure is the natural logarithm of the denominator of the logit model, often termed the "LogSum". The LogSum term is effectively the combined utility provided by the sub-modes of a particular primary mode.

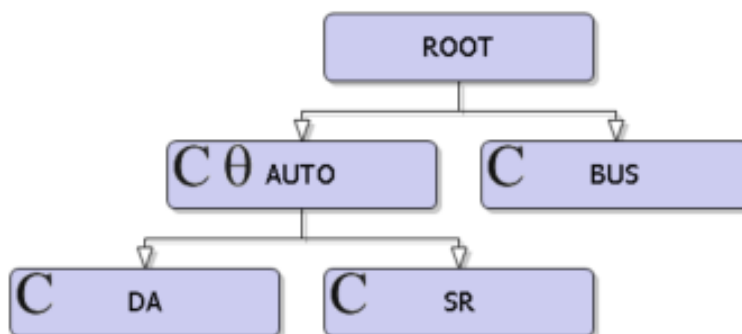

Figure 21: Mode Choice Nesting Structure

There are alternative options for developing the mode choice model coefficient estimates for each of the modal utility expressions, and in the past, it was common to estimate unique coefficients for each model via analysis of combined household travel/on-board transit survey datasets. However, FTA research has shown that spurious models often result. For the PACOG mode choice model, the models by trip purpose used coefficients within the ranges recommended under current best practice guidance by NCHRP 716²⁴ for work trip purposes (see **Table 41** below). For non-work trip purposes, coefficients were borrowed from the North Front Range Model’s non-work trip mode choice model settings for in-vehicle, walk time, and wait times.

Table 41: Pueblo Transit System

Model	In-Vehicle Time	Out-of-Vehicle Time	Walk Time	First Walk Time	Transfer Walk Time
A	-0.021	--	-0.054	-0.098	-0.098

Source: NCHRP Report 716, Table 4.8 Coefficients from survey of MPO mode choice models.

Mode specific constants are then used to calibrate the PACOG mode choice model to fit local conditions. During the calibration process, unique mode specific constants were initially borrowed from a recently completed model for the Flagstaff Arizona MPO, by trip purpose. Then the initial constant settings were adjusted using a heuristic process whereby the full set of constants was factored until the PACOG model produced the correct total transit system boardings. In the future, if observed mode shares by purpose becomes available via a new household travel survey, then these constants can be re-estimated to match observed mode shares by trip purpose. Mode Choice model parameters used in the PACOG model are listed below in **Table 42**.

²⁴ National Cooperative Highway Research Program (NCHRP) Report 716: Travel Demand Forecasting: Parameters and Techniques, January 2014, accessed November 2023.

Table 42: PACOG Mode Choice Model Parameters

HBW1 – Home-Based Work, Income Quartile 1

NEST MODE	AUTO		BUS
	DA	SR	
Coef. INVIT	-0.0210	-0.0210	-0.0210
Coef. IWAIT			-0.0980
Coef. WALKT			-0.0540
Coef. TFRT			-0.0980
Constant	0.0000	-2.6000	-5.5000

HBSE – Home-Based Elementary School

NEST MODE	AUTO		BUS
	DA	SR	
Coef. INVIT	-0.0250	-0.0250	-0.0250
Coef. IWAIT			-0.0375
Coef. WALKT			-0.0540
Coef. TFRT			-0.0375
Constant	-99.0000	0.0000	-2.6000

HBO – Home-Based Other

NEST MODE	AUTO		BUS
	DA	SR	
Coef. INVIT	-0.0250	-0.0250	-0.0250
Coef. IWAIT			-0.0375
Coef. WALKT			-0.0540
Coef. TFRT			-0.0375
Constant	0.0000	-0.1500	-2.8000

HBW2 – Home-Based Work, Income Quartile 2

NEST MODE	AUTO		BUS
	DA	SR	
Coef. INVIT	-0.0210	-0.0210	-0.0210
Coef. IWAIT			-0.0980
Coef. WALKT			-0.0540
Coef. TFRT			-0.0980
Constant	0.0000	-2.6000	-0.6000

HBSS – Home-Based Secondary School

NEST MODE	AUTO		BUS
	DA	SR	
Coef. INVIT	-0.0250	-0.0250	-0.0250
Coef. IWAIT			-0.0375
Coef. WALKT			-0.0540
Coef. TFRT			-0.0375
Constant	0.0000	0.0000	-1.9000

NHBW – Non-Home-Based, Work Related

NEST MODE	AUTO		BUS
	DA	SR	
Coef. INVIT	-0.0250	-0.0250	-0.0250
Coef. IWAIT			-0.0375
Coef. WALKT			-0.0540
Coef. TFRT			-0.0375
Constant	0.0000	-3.0000	-4.2000

HBW3 – Home-Based Work, Income Quartile 3

NEST MODE	AUTO		BUS
	DA	SR	
Coef. INVIT	-0.0210	-0.0210	-0.0210
Coef. IWAIT			-0.0980
Coef. WALKT			-0.0540
Coef. TFRT			-0.0980
Constant	0.0000	-2.9000	-0.7000

HBSH – Home-Based Shop

NEST MODE	AUTO		BUS
	DA	SR	
Coef. INVIT	-0.0250	-0.0250	-0.0250
Coef. IWAIT			-0.0375
Coef. WALKT			-0.0540
Coef. TFRT			-0.0375
Constant	0.0000	-2.5000	-1.7000

NHBO – Non-Home-Based, Other

NEST MODE	AUTO		BUS
	DA	SR	
Coef. INVIT	-0.0250	-0.0250	-0.0250
Coef. IWAIT			-0.0375
Coef. WALKT			-0.0540
Coef. TFRT			-0.0375
Constant	0.0000	-3.0000	-4.2000

HBW4 – Home-Based Work, Income Quartile 4

NEST MODE	AUTO		BUS
	DA	SR	
Coef. INVIT	-0.0210	-0.0210	-0.0210
Coef. IWAIT			-0.0980
Coef. WALKT			-0.0540
Coef. TFRT			-0.0980
Constant	0.0000	-3.2000	-1.0000

HBSU – Home-Based University

NEST MODE	AUTO		BUS
	DA	SR	
Coef. INVIT	-0.0250	-0.0250	-0.0250
Coef. IWAIT			-0.0375
Coef. WALKT			-0.0540
Coef. TFRT			-0.0375
Constant	0.0000	-0.5000	-1.5000

9.3 Mode Choice Model Implementation

The PACOG model applies the eleven individual mode choice models (one for each household trip purpose) via a model specification file. A visual of the mode choice structure showing the connectivity to the skim matrices and matrix cores is shown in **Figure 22**.

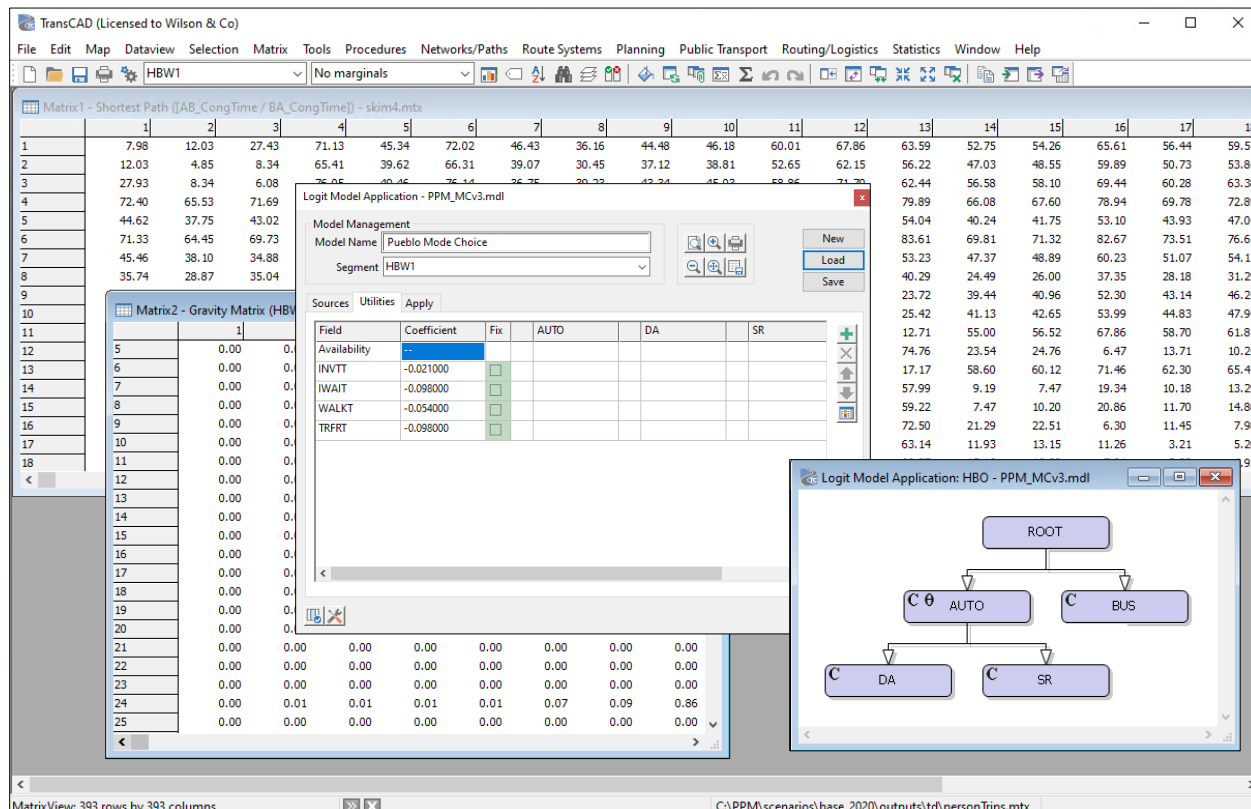

Figure 22: Viewing the Mode Choice Model Structure

9.4 Observed Mode Shares and Model Sensitivity

In addition to general base year mode choice calibration, the mode choice model's sensitivity to different scenarios was also evaluated to ensure that the model is appropriate for forecasting applications. For this, a full model run was conducted for an additional scenario:

- Year 2020 Base travel demand with base roadway network, and improved transit service with headways reduced to half of the current values (shorter wait time for bus). The results show a large increase in bus overall bus mode share, with a disproportionate share of the new riders shifting from drive alone work trips. However, the overall transit share is still under 1%. This is seen as a reasonable response.

The sensitivity results are summarized in **Table 43**.

Table 43: PACOG Mode Choice Sensitivity Test Report

Work Trip Purpose				
MODE -- >	AUTO		BUS	
SCENARIO	DA	SR		
Base 2020	93,873	5,217	687	
Transit Improvement 2020	92,749	5,142	1,888	
Base 2020	94.1%	5.2%	0.7%	
Transit Improvement 2020	93.0%	5.2%	1.9%	
Non-Work Trip Purpose				
MODE -- >	AUTO		BUS	
SCENARIO	DA	SR		
Base 2020	385,011	163,916	1,647	
Transit Improvement 2020	384,364	163,438	2,773	
Base 2020	66.9%	29.8%	0.3%	
Transit Improvement 2020	69.8%	29.7%	0.5%	
Total Trips				
MODE -- >	AUTO		BUS	
SCENARIO	DA	SR		
Base 2020	478,884	169,133	2,334	
Transit Improvement 2020	477,113	168,580	4,661	
Base 2020	73.6%	26.0%	0.4%	
Transit Improvement 2020	73.4%	25.9%	0.7%	

9.5 Post Mode Choice Trip Processing

Auto mode outputs from the mode choice process, by trip purpose, are aggregated into a daily auto trip table. During this step, person trips designated as “auto-drive alone” or “auto-shared ride” are converted to vehicle trips. Drive alone trips are treated as one person per vehicle. Assumptions about persons per vehicle for Shared Ride trips varies by trip purpose as shown in **Table 44**.

Table 44: Shared Ride Persons per Vehicle

Purpose	HBW1	HBW2	HBW3	HBW4	HBSE	HBSS	HBSU	HBSH	HBO	NHBW	NHBO
Average Auto Occupancy	2.23	2.23	2.23	2.23	2.84	2.41	3.88	3.2	3.2	3.2	3.2

9.6 Time of Day Modeling and Directional Split Factors

The resulting vehicle trip matrix remains in production-attraction (PA) format. Next, the vehicle trips are converted from PA format to OD format using the time-of-day percentages. For each of the time periods (AM, PM, OP) the daily auto vehicle table is converted from PA to OD using the following time of day factors by trip purpose; see **Table 45**.

Table 45: Time of Day Factors by Trip Purpose

PURPOSE	AMO	AMI	PMO	PMI	OPO	OPI
HBW1	14.2%	0.5%	1.3%	11.8%	38.0%	34.1%
HBW2	14.2%	0.5%	1.3%	11.8%	38.0%	34.1%
HBW3	14.2%	0.5%	1.3%	11.8%	38.0%	34.1%
HBW4	14.2%	0.5%	1.3%	11.8%	38.0%	34.1%
HBSE	35.6%	0.0%	0.0%	4.0%	19.5%	40.9%
HBSS	41.6%	0.0%	1.0%	3.0%	17.8%	36.6%
HBSU	10.3%	1.7%	3.4%	3.4%	34.5%	46.6%
HBSH	1.9%	0.5%	3.9%	6.3%	39.1%	48.2%
HBO	9.5%	2.1%	3.5%	4.2%	37.7%	43.0%
NHBW	1.1%	5.4%	8.9%	1.3%	37.5%	45.8%
NHBO	6.8%		7.1%		86.1%	
SUT	10.0%		10.0%		80.0%	
MUT	10.0%		10.0%		80.0%	
EXT_AUTOS	10.0%		10.0%		80.0%	
EXT_SUT	6.1%		4.6%		89.4%	
EXT_MUT	6.1%		4.6%		89.4%	

During the am peak hour, 14.2 percent of the HBW trips occurred from home to work, and 0.5 percent occurred from work to home. In the pm peak hour, 1.3 percent of the trips were from home to work, and 11.8 percent of the trips were from work to home. During the off-peak 22 hours, the HBW directional split factors were 38.0 percent and 34.1 percent from home to work and work to home, respectively. The directional split factors for all trip purposes exhibit patterns and relationships that are supported by intuition and logic. Several examples of the temporal spread of trips are given in **Figure 23** through **Figure 27**.

The distribution of home-based work trips by time of day shown in **Figure 23** is characterized by a sharp high peak in the AM, another sharp, somewhat lower peak in the PM and a small but distinguishable peak during the midday.

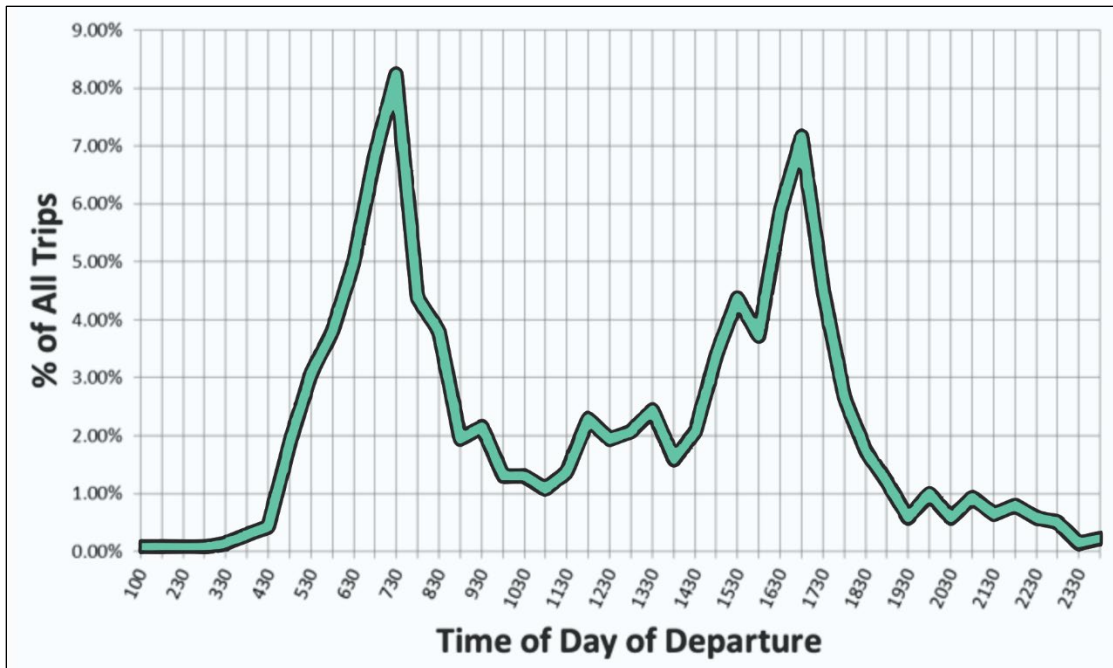

Figure 23: Home-Based Work Time of Day of Travel

The distribution of home-based shop trips by time of day, shown in **Figure 24** is a jagged line with an increasing trend that reaches a maximum in the PM before dropping off.

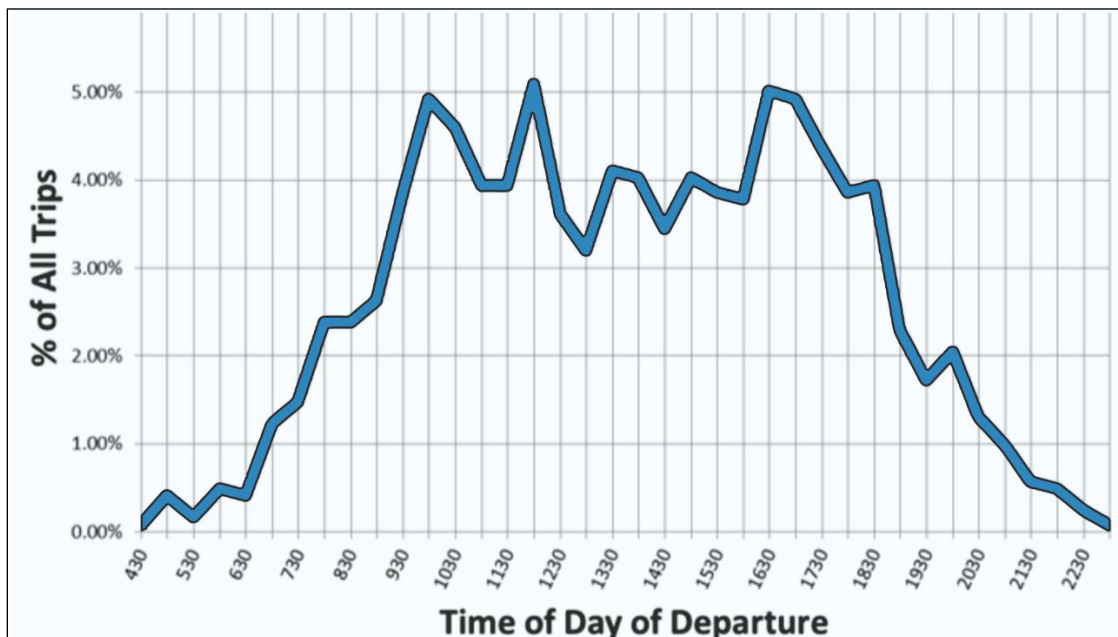

Figure 24: Home-Based Shop Time of Day of Travel

The Home-based other trips, plotted in **Figure 25** show that this purpose peaks sharply, reaching a maximum at approximately 7:30 AM. The distribution peaks again at approximately 3:00 PM.

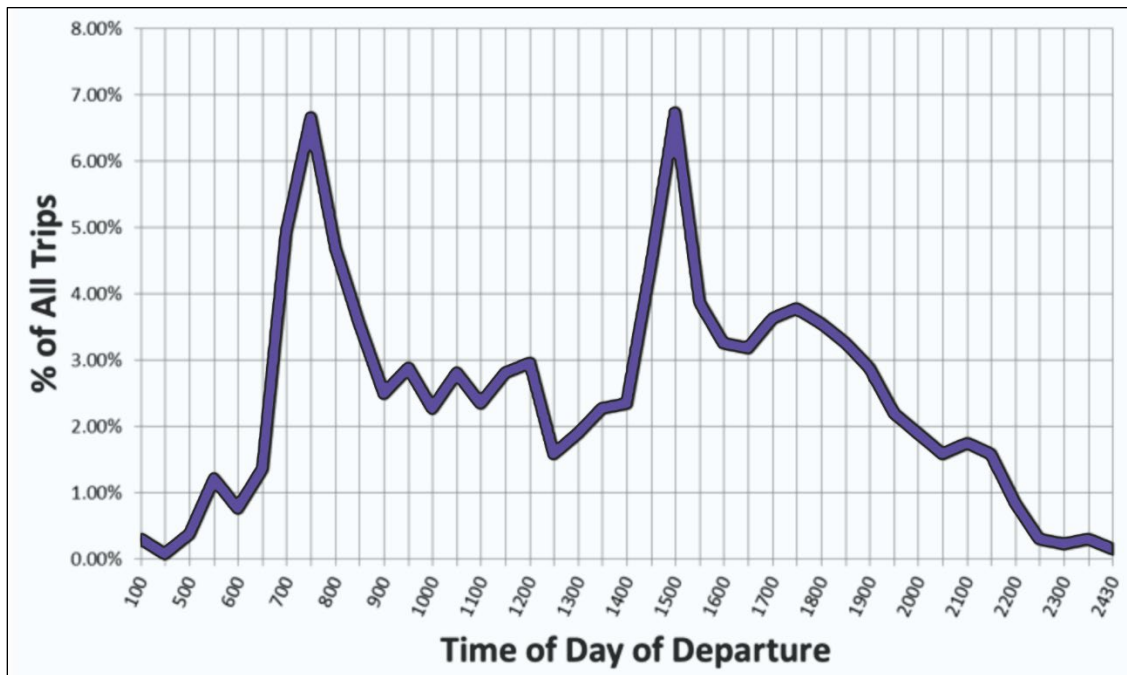

Figure 25: Home-Based Other Time of Day of Travel

The Non-Home-Based trips, shown in **Figure 26** have an early peak at about 7:30 am then maintain a continued presence throughout the day.

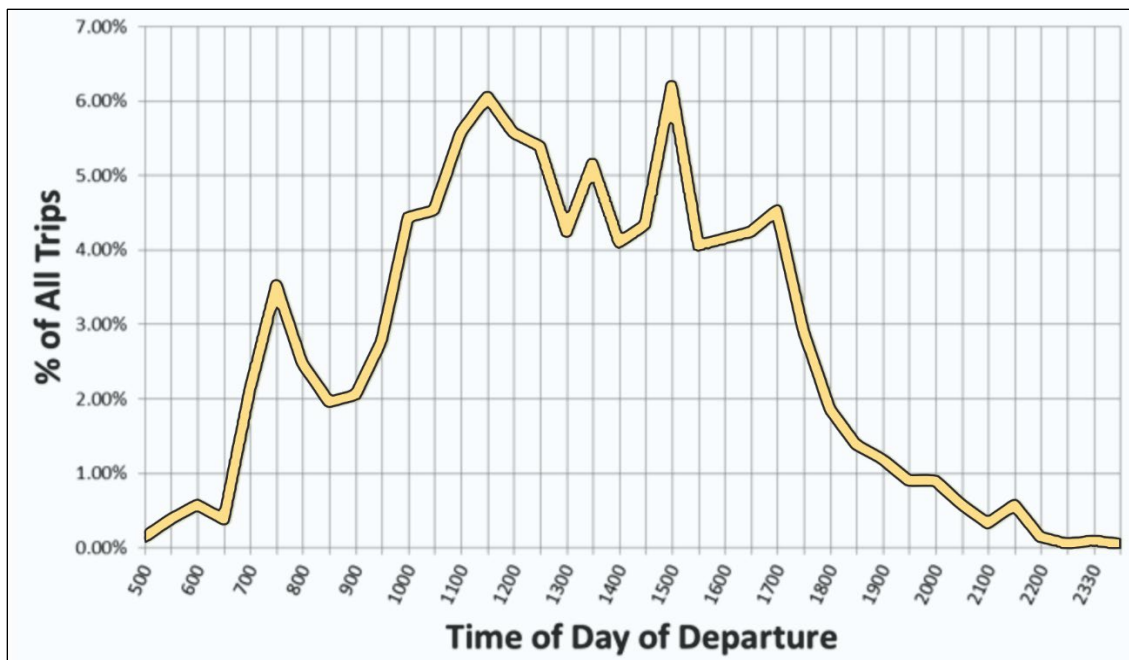

Figure 26: Non-Home-Based Time of Day of Travel

The distribution of all trips by time-of-day as a percentage of the sum of all trips for the 24-hour period is depicted in **Figure 27**.

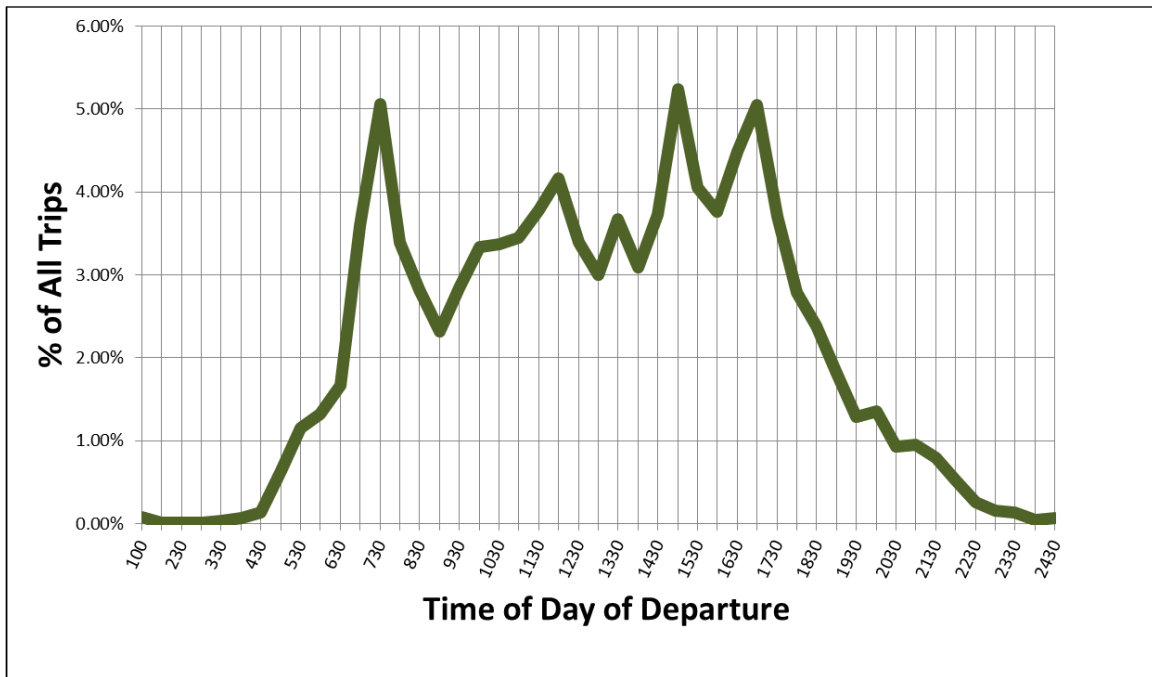

Figure 27: All Trips Time of Day of Travel

The trip tables produced at this point in the modeling process will be assigned to the highway and transit networks since they are now in origin-destination format. The trips have also been segmented by time of day. The results of the time-of-day factoring in vehicle trips for the 2020 validation run are shown in **Table 46**.

Table 46: Auto Vehicle Trips by Time of Day

Time of Day	Vehicle Trips
AM Peak Period Trips	48,365
PM Peak Period Trips	46,672
Off-Peak Period Trips	421,608

10 Highway and Transit Assignment Approach

10.1 Highway Assignment

The traffic assignment process runs for three time periods; am peak hour, pm peak hour, and off-peak hours. The capacity constrained assignment process uses TransCAD's multi-modal multi-class assignment with three vehicle classes, Auto and two truck classes (SUT and MUT). The assignment process is a user-equilibrium with time-period specific capacities and initial travel times pulled from the roadway attributes. Default alpha and beta parameters (0.15 and 4.0 respectively) are used in the volume-delay function. In addition, the volume-delay function uses a passenger car equivalent (PCE) of 1.5 for single unit trucks (SUT) and 2.5 for multi-unit trucks (MUT). The PCE adjustment is only used to determine the link travel time, and the actual SUT/MUT vehicle flow is reported later in the results. The assignment process runs through each of hundreds of iterations, and the volume-delay function computes a congested travel time that affects the shortest time paths used in the next iteration. As roads become congested, traffic diverts to other roadway paths until an equilibrium is achieved.

10.2 Transit Assignment

A daily transit route assignment is included with each model run. Transit assignment uses the daily bus trips from Mode Choice which have been afterward converted from PA to OD format. Transit network files and settings are identical to those set up during Transit Skimming. The daily transit assignment process results in the following outputs:

- Transit Ons and Offs – joins to the transit stops and shows boarding by stop. This file is used to aggregate boardings by route when the Transit Ridership report is requested from the user interface.
- Transit-Related Walk Flows – joins to the road network and shows walk flows resulting from the transit riders accessing/egressing transit.
- Transit Use on Road Network – joins to the road network and shows an aggregation of all person trips using transit on the road layer.
- Transit Flow by Route – joins to the transit route system and shows the number of people on each bus route between each pair of stops.

After a model run is completed for a given scenario, a transit ridership report can be generated from the Maps and Reports tab of the user interface. This report summarizes the total daily bus boardings in the system. Additional bus boarding results by line are provided in the 2020 base model scenario for validation purposes.

11 User Interface, GHG Analysis and Reporting

The PACOG model's original reporting capabilities were updated to work with the new components/updates. Several new reporting outputs were added under the Other Outputs section of the Graphical User Interface, namely:

- Mode Shares – summarizes modeled person trips by each mode and trip purpose into a single output table.
- Transit Ridership – summarizes transit assignment results into boarding by individual bus route and compares with observed boarding counts for the 2020 base and system totals for the future years.
- GHG Link Data – generates a comma delimited database that combines all highway assignment time period outputs for each link. This raw information can be converted for use in a MOVES (EPA air quality model) County Data Inventory run for greenhouse gas emissions.
- Trip Lengths – generates a trip length distribution chart and computes average trip length for each modeled trip purpose and truck type.

Guidance on the application of these reporting tools within the PACOG GUI are available in the “PACOG Travel Demand Model User Guide” prepared in 2024. Of note is the GHG sensitivity module designed to allow PACOG to test GHG reduction scenarios using Work from Home percentages, transit frequency and transit speed.

11.1 Greenhouse Gas Reduction Scenarios

As part of the greenhouse gas analysis capabilities, the PACOG Travel Demand Model user interface allows users to apply some general assumption changes impacting travel demand/mode choice which can be applied in special model scenario runs.

- Adjust Work from Home assumptions by each income quartile – If the model user changes from default values, then the net change is applied at the HBW trip generation step. This could be used to estimate the effects of employers requiring workers returning to in-person office jobs post-COVID. Increases in work from home can be modeled as well.
- Increase Transit Frequency – Allows model users to test the effectiveness of increased transit service via shorter wait times between buses. This is applied as a factor across all bus routes. For example, if the value is changed to 2, then buses would be twice as frequent. If a more complex scenario is desired, then the model user will need to create a separate Transit Route System with the characteristics to be tested (new route, itinerary, frequency and other).
- Improve Transit Speed – Allows model users to test the effectiveness of reducing transit travel times via various improvements (signal pre-emption, separated right of ways, improved boarding). In the model, this is accomplished by changing the In-Vehicle Travel Time (IVTT) encoded on each roadway link. The default setting is transit travel speed is 50% of the auto speed on a given road segment. If the user desires to increase the speed of transit service, then the value would be set to a value greater than 50%.

12 Daily Model Validation

12.1 Observed Traffic Data

Observed traffic in the form of Average Annual Daily Traffic (AADT) for years 2020 through 2023 was collected. The span of time during which the Covid-21 pandemic was active spanned the years 2020 through 2021+ rendering those years of limited use due to the observed suppressed traffic flow. Hence the decision was made to utilize 2022 and 2023 observed traffic to capture a realistic base year representing 2020. The AADT data was collected and stored in a GIS point file then transferred to the TransCAD model highway network for use in validation. Three parent files were used:

- Colorado DOT's Online Transportation Information System (OTIS)²⁵
- Pueblo city traffic counts
- Pueblo County traffic counts

Truck traffic was obtained from OTIS site for both Single Unit (medium-sized) and Multi Unit (heavy or combination) trucks. Over 500 count locations from the three sources were processed for the project. The AADT values from 2020 through 2023 were reviewed for consistency with the established post Covid-21 base asserted to represent 2020. The final traffic data set was joined to prepare a count database that provided coverage throughout the PACOG region. **Figure 28** shows the locations of the traffic counts collected for the project.

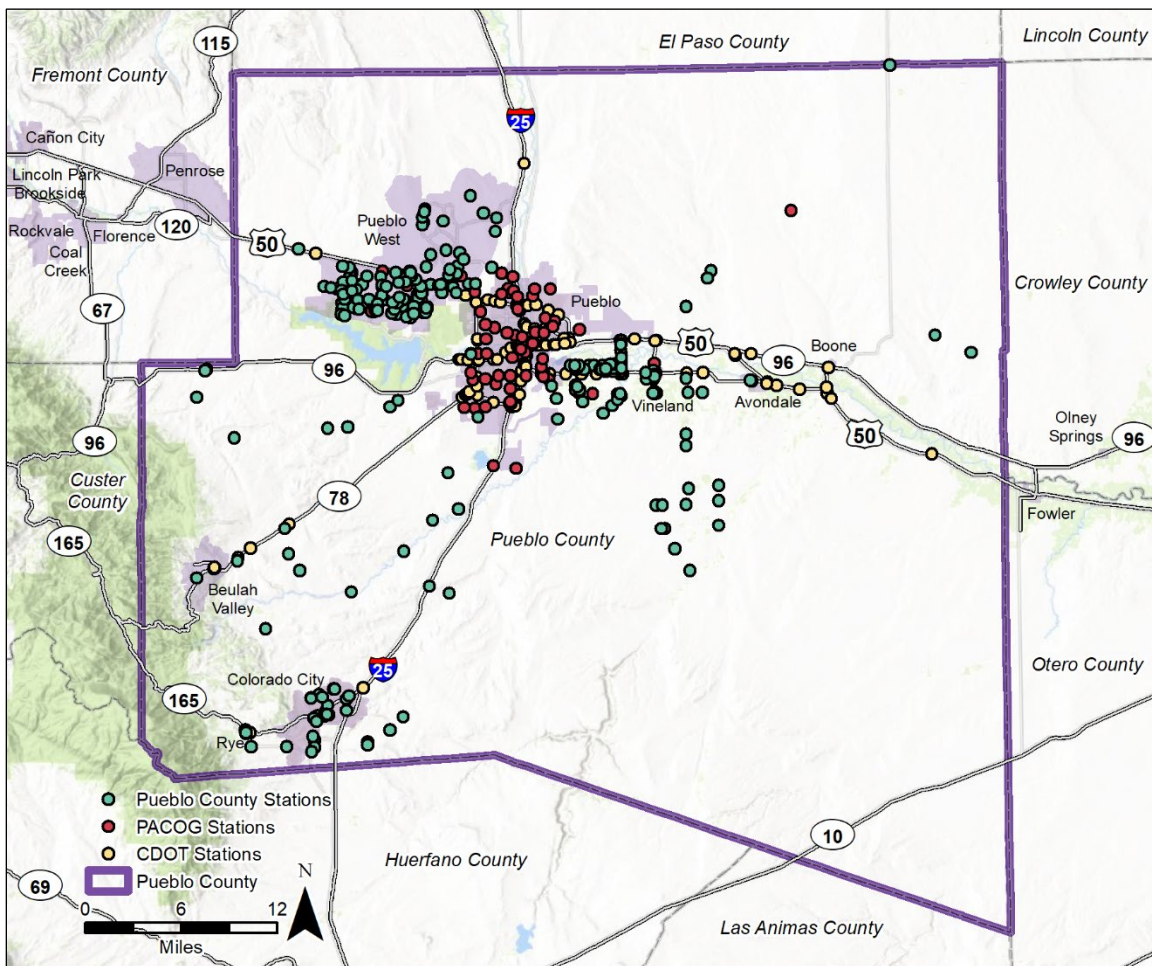

Figure 28: AADT Count Locations

²⁵ Online Transportation Information System (OTIS): <https://dtdapps.coloradodot.info/otis>, accessed December 2023.

A comprehensive review of count values and locations provided a clean dataset for comparison with counts spread evenly throughout the county and across all functional classes of roadways. Care was taken to obtain multiple location counts on all major facilities such as I-25 and U.S. Highway 50. The count records were reviewed for consistency and to remove redundant records and entered as an attribute on the 2020 PACOG highway network file.

12.2 Validation Approach

12.2.1 Traffic Validation Link Categories

All validation was conducted using comparison of modeled to daily traffic. At the completion of the three time period traffic assignments: one-hour am peak, one-hour pm peak and 22 hours off-peak, the PACOG Travel Model time of day flows are summed into daily modeled traffic. This daily attribute includes both commercial vehicles (trucks) by two size classes, and autos from all time periods. The model daily traffic can then be compared to the observed base year AADT in different ways, measuring the goodness of fit across several summary categories. Three summary categories were selected for comparison:

Highway Functional Classification – Four highway functional classifications were identified: interstate, expressway, principal arterial, and minor arterial. Collectors, ramps, and centroid connectors are not included in this summary table.

Volume Range – Traffic counts can also be put into categories based on the volume ranges. This comparison allows the observed traffic itself to define a set of categories. For the PACOG model, volume ranges were established for every 10,000 AADT, except for the first two volume range bins which are 0-5,000, and 5,000 to 10,000 AADT. Ramps and centroid connectors are not included in this summary table.

Screenlines – Six screenlines were developed for the PACOG validation. Screenlines measure the regional traffic flows crossing selected roadways or natural features and provide a cross-check on regional traffic flows. As an example, the U.S. Highway 50 (West) screenline sums all the counts at locations crossing US Highway 50 from north to south and from south to north in the area west of Interstate-25.

12.2.2 Daily Highway Model Validation Tests

The following validation tests were performed on the PACOG Travel Demand Model traffic to validate the daily traffic assignment:

Observed and Modeled Traffic Flows Comparison – This test, which totals the observed and the modeled traffic using observed and counted link flows, is presented by functional classification, volume range, and screenline.

Percent Root Mean Square Error (% RMSE) – This test, which measures the absolute value of the difference between model volumes and observed traffic counts, is where the variability of the traffic counts is most evident. It is presented by functional classification, volume range, and screenline. If the model fit were perfect, the percent root mean square error would be zero; the lower the % RMSE value, the better the model fit.

Volume Range Scatter Plot – Volume range scatter plots are used as a test to provide a visual comparison of the difference between the observed and modeled traffic. Each point represents a traffic count and the model volume from assignment. When the data points conform to the diagonal where the y-axis (model) equals the x-axis (counts), the fit is exact.

12.3 Highway Model Validation Results

12.3.1 Validation by Facility Type

The first test of highway validation was conducted using the category of facility type. Four facility types were analyzed: Interstates, Expressways, Principal Arterials, and Minor Arterials. **Table 47** shows the validation results for these categories. Overall, the daily model flows were about 1% higher than the observed value. Interstates and expressways have a highly accurate percent difference (less than 1%), demonstrating a close fit to observed values on roads where traffic is heaviest. RMSE of 30 shows good fit of modeled to observed traffic.

Table 47: Traffic Validation by Facility Type

Facility Type	Facility Type ID	Number of Observations	Flow Comparison			% Root Mean Square Error
			Sum of Counts	Sum of Flows	% Difference	
Interstate	1	22	537,000	533,142	-0.7	11
Expressway	2	39	732,205	731,330	-0.1	26
Principal Arterial	3	66	927,746	949,910	2.4	35
Minor Arterial	4	20	148,828	158,842	6.7	69
Total		147	2,345,779	2,373,223	1.2	30

12.3.2 Validation by Volume Range

The second test of highway validation is that of volume range as shown in **Table 48**. Volume range operates by establishing intervals of observed values, usually by steps of 10,000 AADT and then using them as categories to compare modeled flows to observed. There are six volume range categories used in the PACOG model. The lowest two categories are subcategories: 0-5,000 and 5,000-10,000 AADT which were established to capture the volume range validation more readily on low traffic facilities.

Overall, the daily assigned volume was 1.2 percent higher than the observed value with a % RMSE of 30. The higher volume classes, 20,000 AADT and above, have the most accurate % RMSE, demonstrating a closer fit to observed values on the facilities where traffic is heaviest. The % Root Mean Square Error (RMSE) values of 30 or higher on segments of less than 10,000 AADT communicates that a large part of the model traffic variation is confined to the lower volume highway segments, which typically are more of a challenge to load evenly in assignment. Of note is the I-25 call-out with a -1% difference model to observed, and a % RMSE of 11 indicating a very close fit on this facility.

Table 48: Traffic Validation by Volume Range

Volume Range	Volume Range ID	Number of Observations	Flow Comparison			% Root Mean Square Error
			Sum of Counts	Sum of Flows	% Difference	
Less than 5,000	1	10	45,229	75,855	67.7	97
5,000-10,000	2	38	272,219	331,645	21.8	54
10,000-20,000	3	61	914,563	931,477	1.8	30
20,000-30,000	4	26	645,768	609,870	-5.6	21
30,000-40,000	5	7	245,000	227,861	-7.0	16
40,000-50,000	6	5	223,000	196,515	-11.9	20
Total		147	2,345,779	2,373,223	1.2	30
<i>I-25</i>	<i>special</i>	22	537,000	533,142	-1	11

12.3.3 Validation by Screenline

The six screenlines developed for the PACOG validation are shown in **Figure 29**. **Table 49** shows the traffic validation using the screen lines. The total of the six screenlines yielded crossing volumes about 1% below the observed total traffic summed from all locations. No screenlines were higher than plus or minus 14% of observed totals from the traffic assignment.

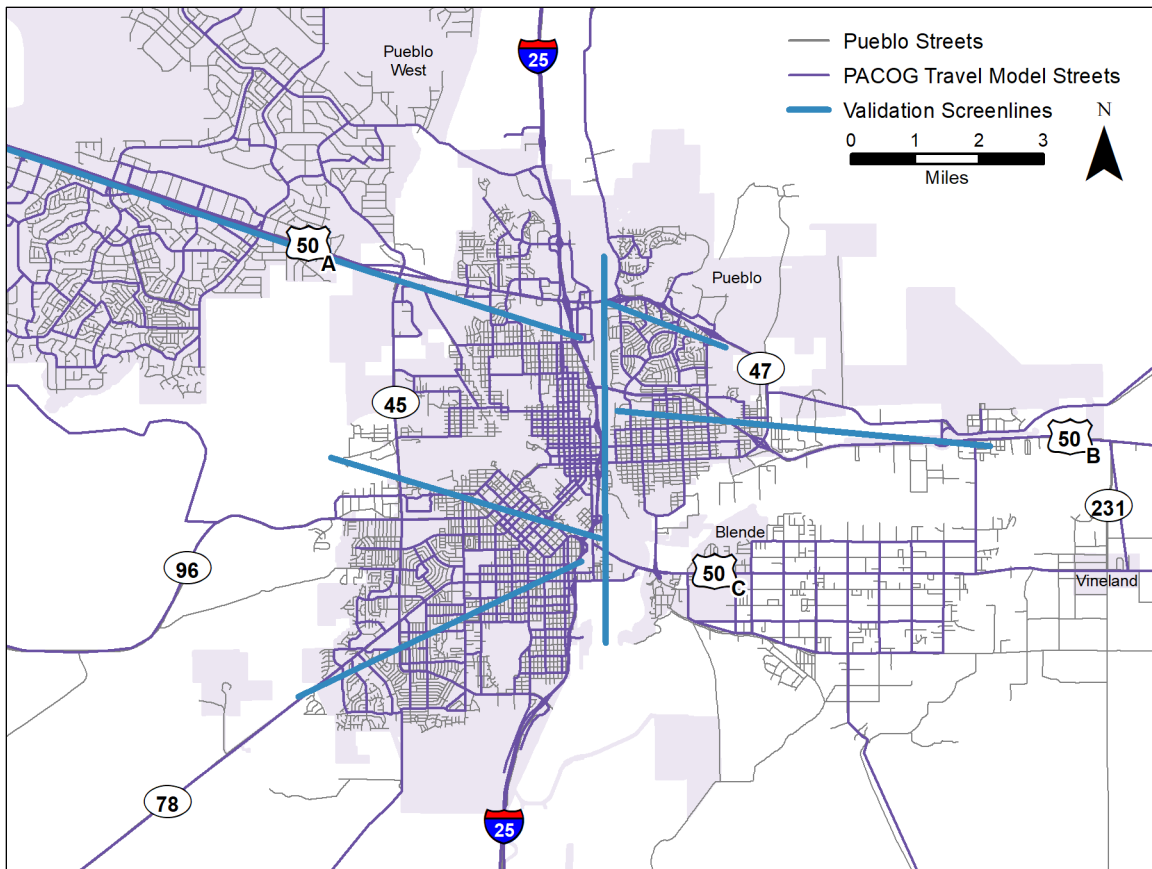

Figure 29: Location of PACOG Travel Model Screenlines

Table 49: Traffic Validation by Screenline

Screenline Name	ID	Number of Observations	Flow Comparison			% Root Mean Square Error
			Sum of Counts	Sum of Flows	% Difference	
N-S Fountain Creek	1	4	64,000	62,450	-2	26
E-W Arkansas River (west of town)	3	6	126,428	129,847	3	8
E-W parallel to CO 47, east of I-25	4	2	10,682	11,147	4	45
E-W, parallel to US 50, west of I-25	5	3	83,465	72,568	-13	14
E-W, parallel to US 50, east of I-25	6	5	36,542	41,674	14	56
E-W parallel to SH 78, southwest part of town	7	2	43,000	44,022	2	3
All Screenlines		22	364,117	361,707	-1	20

12.3.4 Validation by Scatterplot

Figure 30 illustrates the comparison between observed and modeled traffic flow in scatterplot format for all PACOG Travel Model traffic counts (AADT) used for validation. This test shows a good fit of modeled to observed traffic with the data points generally following the diagonal line of x-axis equals y-axis.

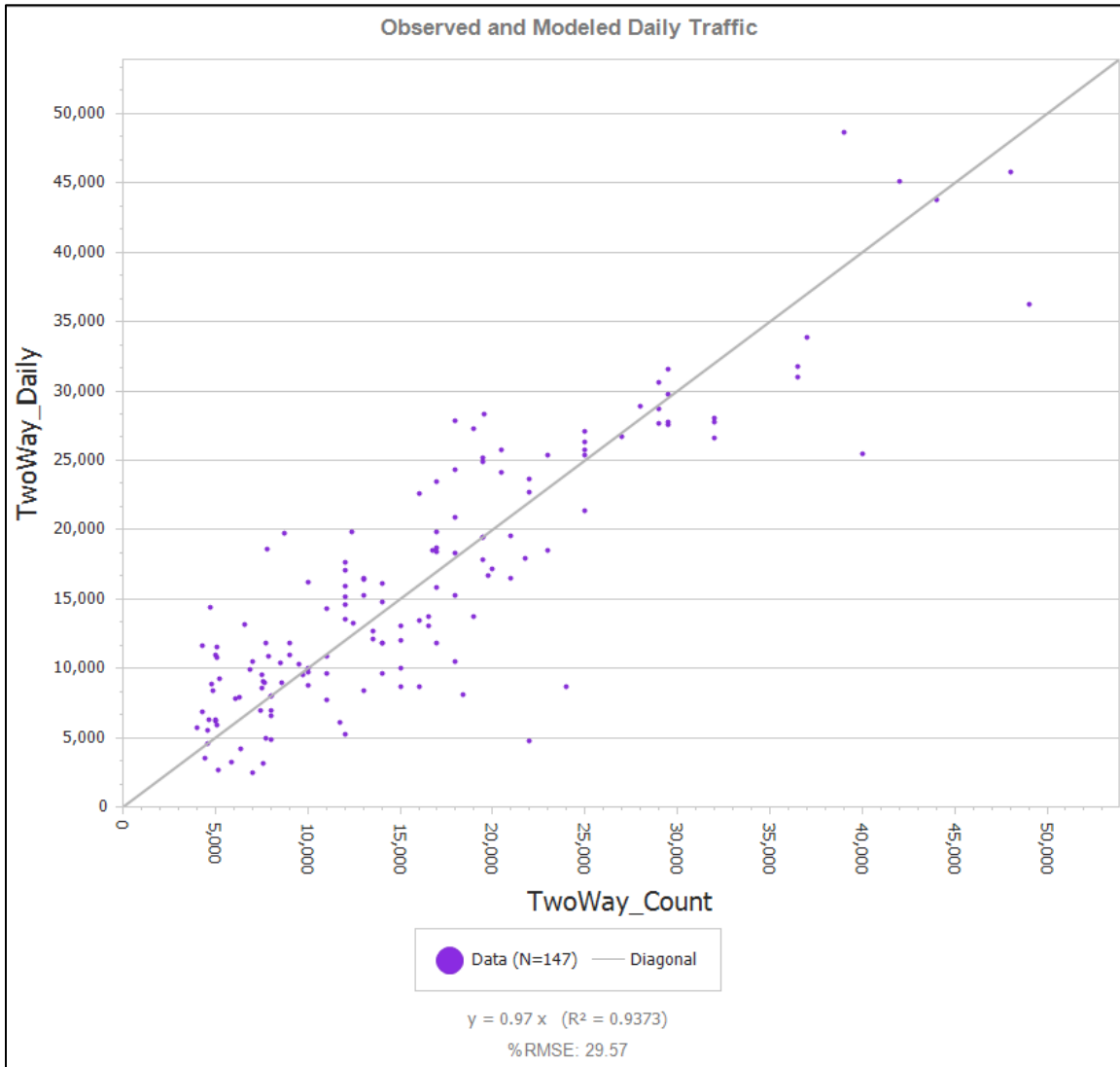

Figure 30: Scatterplot of all Counted Link Segments

12.3.5 Summary of Highway Validation

Three tests were run and on each, the 2020 PACOG Travel model performed well. With respect to relative difference over all counted link segments, an acceptable range within 10 percent (+/-) was set as a target for validation, consistent with standard practices and was exceeded with a 1.2% deviation delivered by the 2020 PACOG model. A Percent RMSE in the low thirties with descending values as the volume class increases is also a target which was met (see **Table 48**). Interstate-25, a key facility in the PACOG region with 22 segments analyzed, performed within 1% of modeled to observed traffic. The highway network 2020 count and model validation, including the review of the full set of model inputs, has yielded a validated 2020 base and a predictive future year travel demand model that is ready for application in the MPO environment.



Pueblo Area Council of Governments
Methodology Report